

---

# **Capturing the Valuation Impact of Investment Delays in Innovation Projects: A Real Options Approach**

---

*The effect of including delay options in project valuations and the moderating role of  
market uncertainty*

By Nicolas Illg

Student ID: 488108

MSc Management of Innovation

Rotterdam School of Management, Erasmus University

July 2018

Coached by: Dr. Jan van den Ende

Co-read by: Dr. Hans Haanappel

# PREFACE

---

## **Disclaimer**

The author declares that the text and work presented in this Master thesis is original and that no sources other than those mentioned in the text and its references have been used in creating the Master thesis.

The copyright of this Master thesis rests with the author. The author is responsible for its contents. Rotterdam School of Management, Erasmus University is only responsible for the educational coaching and cannot be held liable for the content.

## EXECUTIVE SUMMARY

---

The purpose of this study was to analyze the effects of including delay options in real options valuations for innovation projects. Further, we were interested in variables that determine a delay options value, in particular market uncertainty, which we assumed to be a moderator between the delay options value and the project valuation.

We establish the theoretical foundations based on a literature review on the theory of real options methods, delay options, and the costs of investment delays in projects. Based on this theory we develop a project valuation model with a delay option that we call Model 2. Data on real-life radical innovation projects was gathered from five cases that were valued with a real options model including an abandonment option, Model 2, and a Net-Present-Value approach. Additionally, we performed a sensitivity analysis between our model's input parameters and the value of a delay option. Lastly, we used Monte-Carlo simulations and optimization tools to generate optimal solutions of input parameters that maximize a delay options value.

Our findings establish that delay options can lead to a higher real options valuation of radical innovation projects than abandonment options. Especially in projects with high market uncertainty and where the majority of investments happens in later phases, the difference in valuation can be high. Market uncertainty was found to mostly have a positive impact on a delay options value although the relationship was not linear and seems to be moderated by other input parameters of a project. Further, technical uncertainty and the costs of delaying investments have a higher influence on a delay options value than market uncertainty.

The managerial implications of our study are two-fold. First, we argue that a delay options approach can be a useful additional valuation tool for innovation projects. If companies have delay options at their disposal during a project using a delay options approach can provide a more flexible estimate of a project's value than other real options techniques. Especially in situations where other real options approaches do not give a project a positive valuation due to a high chance of project abandonment from unfavorable market developments.

To our knowledge, this is the first study to build a project valuation model incorporating delay options and analyze it on a set of real-life cases in the context of innovation projects. Our findings thereby provide a valuable basis for future research to build on.

# TABLE OF CONTENTS

---

<b>PREFACE.....</b>	<b>I</b>
<b>EXECUTIVE SUMMARY .....</b>	<b>II</b>
<b>LIST OF FIGURES.....</b>	<b>2</b>
<b>LIST OF TABLES.....</b>	<b>3</b>
<b>LIST OF APPENDIXES .....</b>	<b>3</b>
<b>1. INTRODUCTION .....</b>	<b>1</b>
1.1 Research Question .....	2
1.2 Thesis Structure .....	4
<b>2. LITERATURE REVIEW.....</b>	<b>5</b>
2.1 Real options in the context of strategic decision-making.....	5
2.2 Methodologies for evaluating real options .....	6
2.3 The Option to Delay Investment.....	9
2.4 The Cost of Exercising Delay Options.....	10
2.5 Delayed entry and first-mover advantages .....	12
2.6 Uncertainty and Option Value .....	13
2.7 Market and Technical Uncertainty.....	15
2.8 Industry-Specific Real Options Research.....	17
2.9 Main findings.....	18
2.8. Hypothesis .....	19
<b>3. METHODS .....</b>	<b>22</b>
3.1 Rationale for a Case Study Approach .....	22
3.2 Framework.....	23
3.3 Data Collection and Analysis .....	23
3.4 Validity.....	24
3.5 Reliability .....	25
3.6 Limitations.....	25
3.7 Valuation Models.....	26
<i>Valuation parameters.....</i>	<i>27</i>
<i>The Net Present Value Approach:.....</i>	<i>29</i>
<i>Real Options Valuation in a Trinomial Lattice.....</i>	<i>30</i>
<i>Calculating the Option Values.....</i>	<i>35</i>
<b>4. RESULTS .....</b>	<b>41</b>
Case 1: Offshore Oil-Drilling Technology for Salmon Farming.....	42
Case 2: Mobile Asphalt-Mixing Pontoon.....	47

Case 3: Robotization of CNC Milling and Drilling Factory .....	50
Case 4: Print Publication for an Unserved Niche .....	53
Case 5: Web-Solution for Motorsports Image Licensing.....	56
4.1 Case Evaluation – Summary.....	59
4.2 Case Evaluation – Sensitivity Analysis.....	61
4.3 Sensitivity Analysis.....	64
4.4 Optimization .....	67
<b>5. DISCUSSION .....</b>	<b>71</b>
5.1 Market uncertainty and delay options .....	72
5.2 The Drivers of a Delay Options Value.....	73
5.3 Impact of a Delay Option on Project Valuation.....	74
5.4 Theoretical Contributions and Implications .....	75
5.5 Limitations.....	76
<b>6. CONCLUSION.....</b>	<b>78</b>
<b>REFERENCES .....</b>	<b>79</b>
<b>APPENDIX.....</b>	<b>82</b>

## LIST OF FIGURES

---

Figure 1: Binomial Option Tree adopted from Cox et al. (1979) .....	7
Figure 2: Example of a Trinomial Tree.....	9
Figure 3: Framework for determining the impact of a delay option on a real options valuation .....	23
Figure 4: Parameters of project used for explanation purposes.....	27
Figure 5: NPV Calculation Logic.....	29
Figure 6: Example of a Trinomial Market Value Tree.....	31
Figure 7: Distribution of final market values in the lattice compared to the NPV scenarios. ...	33
Figure 8: Different Real Options Logics in case of a negative Option Value.....	37
Figure 9: Graphical Illustration of the Delay Option Calculation Procedure in Model 2. ....	39
Figure 10: Project Parameters Case 1.....	43
Figure 11: NPV Calculation Case 1 .....	44
Figure 12: Market and Delay Tree for Case 1 for both Model 1 and Model 2.....	45
Figure 13: Valuation Outcomes Case 1. All Values in Million Euros.....	46
Figure 14: Project Parameters Case 2.....	48
Figure 15: Market and Delay Tree for Case 2 for both Model 1 and Model 2.....	49

Figure 16: Valuation Outcomes Case 2. All Values in Million Euros.....	49
Figure 17: Additional Information Case 3.....	50
Figure 18: Project Parameters Case 3.....	51
Figure 19: Market and Delay Tree for Case 3 for both Model 1 and Model 2.....	52
Figure 20: Valuation Outcomes Case 3. All Values in Million Euros.....	52
Figure 21: Additional Information Case 4.....	53
Figure 22: Project Parameters Case 4.....	54
Figure 23: Market and Delay Tree for Case 4 for both Model 1 and Model 2.....	55
Figure 24: Valuation Outcomes Case 4. All values in Million Euros.....	55
Figure 25: Additional Information Case 5.....	56
Figure 26: Project Parameters Case 5.....	57
Figure 27: Market and Delay Tree for Case 5 for both Model 1 and Model 2.....	58
Figure 28: Valuation Outcomes Case 5. Values in Million Euros.....	58
Figure 29: Overview of Case Valuation Results.....	59
Figure 30: Sensitivity Analysis for Case 1.....	61
Figure 31: Sensitivity Analysis for Case 2.....	62
Figure 32: Sensitivity Analysis for Case 3.....	62
Figure 33: Sensitivity Analysis for Case 4.....	62
Figure 34: Sensitivity Analysis for Case 5.....	63
Figure 35: Market Tree Nodes from which Sensitivity Analysis Scenarios were derived.....	65
Figure 36: Sigma vs. Delay Option Value in Scenario 2.....	66
Figure 37: Spider Plot for Input Parameters in Scenario 2.....	67
Figure 38: Simulation Set 1 for delays in different scenarios.....	68
Figure 39: Simulation Set 2 for delays in different scenarios.....	69
Figure 40: Simulation Set 3 for delays in different scenarios.....	70

## LIST OF TABLES

---

Table 1: Total expected final market values in an NPV-calculation versus a trinomial lattice.....	34
Table 2: Additional Information Case 1.....	42
Table 3: Additional Information Case 2.....	47
Table 4: Inputs for Sensitivity Analysis.....	64
Table 5: Summary of Acceptance or Rejection of Hypothesis.....	71

## LIST OF APPENDIXES

---

Appendix A: NPV Calculation Case 2.....	82
Appendix B: NPV Calculation Case 3.....	82
Appendix C: NPV Calculation Case 4.....	83
Appendix D: NPV Calculation Case 5.....	83
Appendix E: Sigma vs. Delay Option Value Scenario 1.....	84

Appendix F: Spider Plot for Input Parameters in Scenario 1. ....84  
Appendix G: Sigma vs. Delay Option Value Scenario 3. ....85  
Appendix H: Spider Plot for Input Parameters in Scenario 3.....85  
Appendix I: Sigma vs. Delay Option Value Scenario 4.....86  
Appendix J: Spider Plot for Input Parameters in Scenario 4.....86

## Notation

$t$  – A point in natural time;

$T$  – Year needed to bring a project to market;

$I_t$  – Investment required at point  $t$ ;

$r$  – Risk-free interest rate;

$q$  – Dividend yield;

$\sigma$  – Market Volatility;

$l$  – Permanent loss of market share in percent;

$u$  – Factor of an upward movement;

$d$  – Factor of a downward movement;

$m$  – Factor of a maintain movement;

$P_{I,t}$  – Probability technical development succeeds at point  $t$ ;

$P_u$  – Probability of an upward movement;

$P_m$  – Probability of a maintain movement;

$P_d$  – Probability of a downward movement;

ECV – Estimated Commercial Value of a Project;

ECV<sub>D</sub> – Estimated Commercial Value with Model 2;

ECV<sub>A</sub> – Estimated Commercial Value with Model 1;



# 1. INTRODUCTION

---

Due to the ever faster pace the world is changing at, innovation has become a focus for many companies. New technological developments and shifts in the institutional setting of the organization continually drive change in consumer tastes. This requires a company to innovate in order to keep a competitive advantage over its competitors or even just to survive.

To stay innovative, companies frequently need to pursue risky innovation projects. They thereby expose themselves to high amounts of uncertainty, as often neither the direction the target market moves in nor the technological outcomes of product development are predictable. Due to constrained budgets, companies can only ever pursue a limited number of such projects. It is therefore paramount to determine which innovation project promises the highest-returns, in the face of uncertain outcomes.

The most commonly used valuation methodology used by companies to evaluate innovation projects is the Net-Present-Value (NPV) method. For calculating NPV, financial practitioners estimate future revenue streams and costs. The earnings are then discounted to today's value via a set discount rate. However, using this method frequently leads to an undervaluation of innovation projects due to the high uncertainty regarding their outcomes (Myers, 1984). Especially in radical innovation projects, which are often marked by especially high uncertainty, using an NPV method is not suitable. Hence, there is a need for better valuation tools to capture these uncertainties (Myers, 1984). Recent research has argued that a real options approach might be better suited for valuing radical innovation projects than the NPV-method.

Using Real options in project valuation is derived from options methodologies in financial markets. There, an option gives the buyer, or so-called holder, of an option the right but not the obligation to purchase a specific asset at a pre-specified price. To determine the price of an option, financial models consider its value in different market scenarios including their likelihood of occurring. This logic can be transferred on the valuation of innovation projects with the use of a real options methodology. Thereby, the value of the investment under different market scenarios is decided and the likelihood of each scenario occurring assessed. Recent research has also incorporated risks of technical failure at each investment stage of a project (Van Den Ende, 2016).

When applied to the valuation of innovation projects, current research makes use of binomial models for calculating an innovations possible values in the face of different market scenarios and technical outcomes over multiple project stages. Previous research has been done on the effect of including the option to abandon an innovation project at several stages in its lifetime. This option is crucial if a technical failure arises or the market develops unfavorably.

However, abandoning or continuing a project are not the only types of options available to companies. Instead, managers also face the option to defer any further steps in a project, by delaying an investment required to proceed from one project phase to another. (Ragozzino, Reuer, & Trigeorgis, 2016). The value of this option becomes apparent when looking at innovation projects with multiple sequential investments being performed under market uncertainty. Markets are volatile, and there is uncertainty regarding their future development. If a market develops unfavorably in one time period, it might move into a more favorable state in the next period. Delaying an investment and applying a wait-and-see strategy in regard to the market development can allow a company to capture additional value from a project.

Moreover, exercising the option to delay an investment under unfavorable market conditions might prove to be a better option in some circumstances than abandoning an innovation project. Specifically, in radical innovation projects, which often target highly volatile markets. In those markets, movements from one period to the next can be big and therefore influence the commercialization value of a project considerably. This might lead to an upside value of delaying.

## **1.1 Research Question**

Currently, only very few studies have been done on the effects of investment delays on the outcome of real options valuations. Hence, there is unclarity as to how adding a delay option into a real options model will impact project valuations and what factors do influence this option's value. This research aims to study these effects by building a real options model that includes a delay option and analysing how the option value changes in different settings. Moreover, we compared these valuation results against the results achieved from applying a traditional real options approach with the option to abandon a project.

This research will first establish the theoretical fundamentals of real options literature in general and related to delay options in specific. Moreover, we will outline the potential costs associated

with delaying investments as these delays might have an impact on the final market value of a project. Following this theory, we developed a model suitable to be applied by practitioners to account for possible project delays with a real options method.

As we were interested in potential scenarios where such delay options are especially relevant, we analysed the impact of different input parameters on the options value and the model's behaviour. Specifically, we were interested in the impact the concept of market uncertainty has on the value of a delay option. We assume that the options potential value arises from the volatility of markets, that gives rise to a chance on higher revenues if a project is delayed.

Further, we will try to answer if there are other drivers of a delay options value and how they compare in importance to market uncertainty. Specifically, we were interested in the potential costs an investment delay has in terms of future revenues from a project and how this cost affects a delay options value.

In light of all the above, our research was directed to answering the following questions:

- 1) *'What is the impact of investment delays within a real options model on the valuation of an innovation project?'*
- 2) *'What is the impact of market uncertainty on the value of a delay option and is it the most important value driver?'*
- 3) *'How do costs associated with an investment delay impact the value of a delay option and the overall project valuation?'*

By answering these questions, we aim to give managers an insight as to when they should consider delay options in their real options project valuations. We expect the here developed model to give managers a better basis for decision-making compared to a traditional abandonment-only real options approach. Specifically, in innovation projects which would not be pursued when both following a convention NPV-approach as well as when only considering abandonment options.

## **1.2 Thesis Structure**

Chapter 2 provides an extensive review of the literature on real options, delay options, the waiting cost associated with project delays and the relationship between uncertainty and option values. Chapter 3 presents the methodology that was used in this research. Specifically, we will describe the real options model we developed to conduct our research and its limitations. The results and discussion of this study can be found in Chapter 4 and 5. Besides a case evaluation, these chapters also describe the dynamics of our real options model via a sensitivity analysis and the results of several Monte-Carlo simulations with delay options. Lastly, in Chapter 6, we highlight the conclusions drawn from our research project.

## 2. LITERATURE REVIEW

---

Much research has been conducted in the field of real options. Different streams of literature have thereby researched different aspects, models, and applications of real options methodologies. Many studies have researched whether real options are actually used in companies but are only based on surveys and managers perceptions of their approaches to project valuation (Hartmann & Hassan, 2006; McGrath & Nerkar, 2004). Other studies have researched the effects of applying real options methodologies in projects over different industries (Lee, Shyu, & Dai, 2009; R. G. McGrath, 1997). The premise is that using a real options methodology yields a higher value in some kinds of projects than others. This could specifically be true for innovation projects, as real options approaches allow to account for the high outcome uncertainty in these projects better than traditional NPV-methods. An important reason why innovation projects are evaluated with real options is that the approach allows incorporating the flexibility of abandoning the project at different stages if conditions turn unfavourable. This abandonment usually is done by not performing an investment that is required to continue a project that requires multiple sequential investments to succeed (Copeland & Tufano, 2004).

Plenty of research has been done on these abandonment options, however, research so far fails to capture the value of the option to delay any of these sequential investments. While several researchers provided an intuition that delaying an investment can be a financially opportune choice when a project's outcomes are uncertain, no efforts have been made to implement such an option within a practical project valuation method. Moreover, research fails to address the question what the actual impact of incorporating such an option in a project valuation is. This research tries to fill this gap by developing a practically implementable valuation approach to capture the value of delay options in innovation projects and measure its impact.

### **2.1 Real options in the context of strategic decision-making**

The first study to explore the link between financial options and real-life investments opportunities was Myers (1984). In the study, the authors argue that strategic planning, committing the firm's resources across lines of business, should be complemented by financial theory to optimize resource allocation. Yet instead, Myers identifies a gap between financial and strategic analysis in firms investment decisions. The author delivers three explanations as to why this gap exists. The first being that finance and strategy have a difference in language

and culture. Secondly, that discounted cash flow (DCF) analysis has not been accepted in strategy due to improper application. Lastly, Myers argues that DCF analysis has shortcomings in evaluating strategic projects, even if applied properly. DCF analysis has a bias towards favouring short-lived, low-risk projects and is less helpful in evaluating projects with substantial growth opportunities and high risk (Myers, 1984). It tends to understate the option value associated with growing and profitable lines of business. Therefore, financial theory should be extended by developing real options approaches for evaluating such projects. Firms can then substitute their DCF analysis for a real options approach to value innovation projects.

Ragozzino et al. (2016) argue in their literature review along a similar line of reasoning as Myers (1984) did. The authors conclude that in the field of real options there are still fundamental theoretical differences and remaining gaps between financial economics and strategy research. Despite the tremendous potential for academics and practitioners, empirical work to date has not been able to bring conclusive evidence on the merits of real options (Ragozzino et al., 2016). The authors argue that this is due to financial economics and strategy having worked in quasi-independent directions over the years and that neither has managed to do a holistic job on its own. Ragozzino et al. (2016) believe that future research should focus on the firm or the business unit level as the unit of analysis and it should center on contexts in which valuation is crucial to strategy execution. Specifically, research should focus on researching the various options available to companies, their value at the portfolio level and the optimal timing of exercise. This research builds on the suggestion by Ragozzino et al. by deriving a methodology to value delay options and the contingencies of exercising them. Which mathematical methodologies are best used to derive the value of different kinds of real options is not definitely answered in research yet.

## **2.2 Methodologies for evaluating real options**

To derive the value of a real option Myers (1984) suggests that the logic of financial options can be applied. This can be done with the Black-Scholes model which is commonly used to price financial options and corporate liabilities such as common stock, corporate bonds, and warrants (Black & Scholes, 1973). However, this model does not produce optimal results when evaluating real options. A reason for this, is its complicated underlying mathematics.

$$C(S_0, t) = S_0 N(d_1) - K e^{-r(T-t)} N(d_2)$$

*Equation 1: Black-Scholes Model*

Ragozzino et al. (2016) argue that while financial options can be valued using the Black-Scholes formula simply by inputting the appropriate parameters, valuation is not quite as straightforward for real options. New R&D projects are unlikely to have historical information of past returns from which forward-looking volatility can be inferred. An information needed to use the Black-Scholes Model. Instead, subjective managerial estimates of forward values under high, likely and pessimistic scenarios must be derived (Ragozzino et al., 2016). Further, using the Black-Scholes Model requires the use of advanced mathematics, which often obscures the values of the underlying economics (Cox, Ross, & Rubinstein, 1979). This makes it difficult for managers to apply real option methodologies based on Black-Scholes. So, while real options are able to overcome several shortcomings of traditional DCF-methods as stated by Myers (1984), their applicability is contingent on the availability of easy-to-use valuation models. Specifically, for radical innovation projects, where valuation parameters are highly vague, real options methodologies based on the Black-Scholes model are unfitting.

To address the complexities of the Black-Scholes method in valuing financial options, Cox, Ross and Rubinstein (1979) have developed the so-called binomial-option pricing model (CRR-Model) as an alternative. While the underlying assumptions about an assets future price movement are the same for both models, the CRR-Model is mathematically based on a so-called lattice. The resulting difference is, that the CRR-Model is a discrete time model, while Black-Scholes is a continuous time model. (Lewis, Eschenbach, & Hartman, 2007).

Cox, Ross and Rubinstein (1979) argue that their model gives rise to a simple and efficient numerical procedure for valuing options for which premature exercise may be optimal and emphasize its generalizability to other valuation contexts. Specifically, in real options, the CRR-Model has been gaining attention as it is based on an option tree that can also be used to model the value of a real-world asset over time. An example of a binomial tree can be seen in Figure 1.

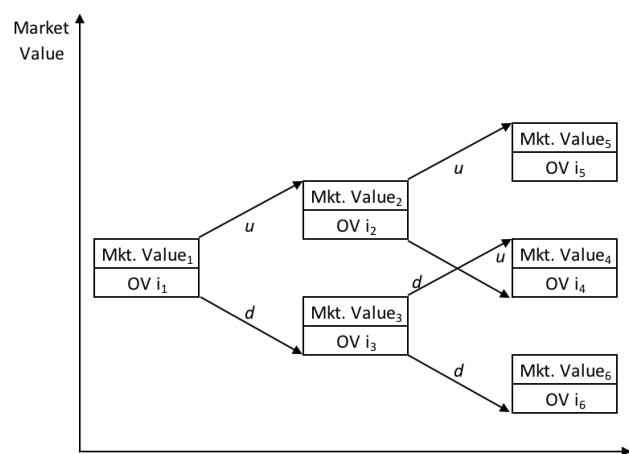

Figure 1: Binomial Option Tree adopted from Cox et al. (1979)

Building on the CRR-Model for financial options, Copeland and Tufano (2004) have created a binomial model that can be used to value projects with a real options logic. They argue that critics of real options approaches often point out to the big differences between relatively simple financial options and highly complex real options. The main differences mentioned thereby are twofold. Firstly, the information to value financial options is much more readily available than for real options. Secondly, the value of the underlying asset of a real option is not always known. Based on this, critics argue that it is practically impossible to apply financial models such as Black-Scholes to real-option decisions. Copeland and Tufano (2004) acknowledge that options embedded in management decisions are far more complex and ambiguous than financial options. However, they point out that the right valuation models can effectively capture the most complex real options accurately (Copeland & Tufano, 2004).

The bulk of problems with real-options analysis stems from the misuse of the Black-Scholes-Merton model for option valuation. The model was developed to price European-style options but never intended for use with more complicated derivatives. Attempts to use it for real options analysis are therefore misguided and inappropriate (Copeland & Tufano, 2004). To overcome this issue, they advocate the use of their adjusted binomial model for valuing real options. As it is based on a lattice-method, it uses simple algebra and thereby solves the lack of transparency and flexibility the Black-Scholes model suffers from according to the authors.

Further, due to its lattice-based nature, their binomial model can, just like in a decision-tree, capture opportunities to take multiple decisions over several points in time (Copeland & Tufano, 2004). This methodology can be applied for innovation projects such as R&D projects well, as it splits investments over time and allows for evaluating an abandonment choice at every stage of the project and thereby accounts for the managerial flexibility needed in such projects. However, a downside of using binomial models is that they assume that an asset's value always either goes up or down over time. When trying to value any asset whose price can also remain unchanged over time, they are therefore not ideal.

For such cases, Boyle (1986) has developed a so-called trinomial model which is like binomial models based on lattice techniques. The advantage of his model is that it can model asset prices to remain constant as well and thereby provides more nuanced valuations for some assets. An example of the models underlying trinomial tree can be seen in Figure 2.



Ragozzino et al. (2016) as well as Copeland and Tufano (2004) stress the importance of using methodologies in real options that can accurately capture a project’s contingencies. As we will discuss in our methodology section, a trinomial lattice provides several advantages in capturing a delay options value. We will, therefore, base our methodology on such a lattice to model the option to delay within a real options framework. This will allow us to accurately capture project contingencies, as emphasized by Ragozzino et al. (2016). In general, a significant challenge in selecting the appropriate methodology for a real-options model is to incorporate all relevant options for a project as they determine the modeled amount of managerial flexibility.

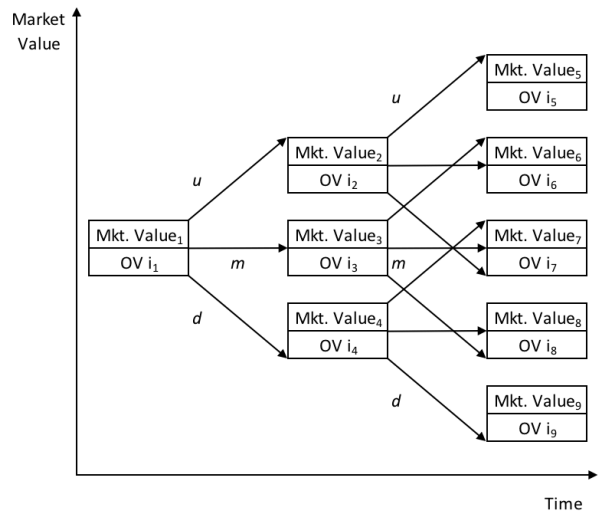

Figure 2: Example of a Trinomial Tree

### 2.3 The Option to Delay Investment

Managerial flexibility in real options models is derived from the different types of options managers have at their disposal during a projects lifetime. In literature, several types of options available to managers have been identified over the last decades related to project investments. These include the option to delay, abandon, contract, or expand an investment, or switch investment to an alternative use (Trigeorgis, 1993). The underlying assumption is that each type of option can capture some value depending on the specific project circumstances.

This research will focus on the option to delay investment. More specifically, we will look at projects with several staged investments and how a delay of any of these investments influences a real options valuation. We will refer to such delays in investments as *delay options*. We thereby define the option to delay as a ‘*delay of a sequential investment, within a staged project*’. Moreover, we will use the term ‘*to exercise a delay option*’, to describe a firm choosing the to delay an investment and thereby defer a project’s completion into the future.

The first study to explore the potential value of delaying an investment in a real options approach was done by McDonald and Siegel (1986). In the study, the authors argue that firms are faced with the mutually exclusive choice of taking an irreversible investment into a project today or in the future. As time passes, uncertainty about the project’s value and the cost of the

project is being continuously resolved (McDonald & Siegel, 1986). The value of the option to delay is thereby twofold. Firstly, exercising the option allows firms to avoid opportunity costs, specifically from sunken-costs, associated with making an irreversible investment when substantial uncertainty about the future exists. Secondly, delaying an investment allows some of this uncertainty to resolve as time passes by and thereby get a clearer picture of the possible outcomes. The authors infer that the option to delay investment can potentially provide a higher benefit if more outcome uncertainty as to the potential future cash-flows exists.

McDonald and Siegel (1986) argue, however, that delaying investments also bears costs and risks. They give the example of innovation in High-Tech industries, where delaying a product introduction might enable competitors to launch better products, rendering the delaying firms product worthless as a result. The risk of waiting is thereby, that competitors can take the lead in the market as a result of exercising a delay option. However, while investments are irreversible, the decision to delay an investment is reversible. The study concludes that in a stochastic real options model, the upside value of an investment diminishes as a delay is exercised, due to the risk of competitors gaining market share.

While McDonald and Siegel did not empirically test their findings, their study emphasizes a potential trade-off between the costs and benefits of a delay. A delay option allows for market uncertainty to resolve while at the same bearing the risk of incurring economic disadvantages from a competitor's early market entry. The main risk thereby arises from a later commercialisation of a product when investments are delayed. In radical innovation projects, which are characterized by high uncertainty, exercising a delay option could be a rational choice if the risk of competitive pre-emption, and a permanent loss of market share, is not too high. Yet even though McDonald and Siegel (1986) proposed already more than 30 years ago, that a delay option entails costs, little research has tried to operationalize this cost on a project-level applicable for managers. Instead, the cost of delaying investments is often ignored in real options research, leading to potentially flawed valuation outcomes (Eschenbach, Lewis, & Hartman, 2009).

## **2.4 The Cost of Exercising Delay Options**

Ignoring the cost of waiting when delaying investments can lead to wrong decisions about an investments value and thereby project failure. Lewis et al. (2007) performed a case study on a pharmaceutical company's problem whether to build production facilities for a yet unapproved

drug. Within the study, the company was facing the choice whether to build facilities immediately or to wait for regulatory approval first and delay investment by two years. Thereby, receiving all cash-flows later but avoiding the risk of building the factory and not gaining approval. The authors compared the different valuations for both choices, with an NPV-methodology versus a real options calculation using the Black-Scholes method. They find that if no cost is added to the delay option it is valued as more favourable than an NPV calculation. In a second calculation, they operationalized the cost of delaying as the difference in the NPV when the cash flows are gained immediately, versus when the project is delayed by two years. In this case, the value of the option to delay the project was reduced from \$28 Million to \$8 Million, making a delay *less* favourable than building immediately. Following, they conclude that the costs of delaying can kill the value of a delay option (Lewis et al., 2007) and has to be accounted for in real options models. When valuing innovation projects with real options including delays, it is therefore important for managers to consider what costs could result from a delay. However, the study by Lewis et al. (2007) provides no further guidance on a more practically usable and sophisticated model to determine the cost of delay.

Research by Eschenbach et al. (2009) tries to fill this gap in the context of real options in engineering projects. In their study, they argue that for financial options not considering any costs to delaying might be feasible, but this is not the case for real options. In the area of financial options, the holding times are often very short and the only holding cost if exercise is delayed, are lost dividends due to not owning a stock in time. However, in engineering projects, delay times can often span years and the following costs can lead to a change, instead of only a delay, in the expected cash flows. Further, a much broader range of possible costs can be caused by changes in technology, regulations, market conditions and or loss of market share (Eschenbach et al., 2009). Just assuming cash flows are delayed is therefore not sufficient when valuing any sort of project with delay options.

Eschenbach et al. (2009) propose three models to calculate delay costs as a loss of interest from receiving cash-flows later in time. However, they argue that how this cost is actually determined must depend on a project's target market contingencies. They also state limitations for their models. Specifically, that delay costs arising from competitors entering the market earlier are not considered. This potential consequence of a delayed entry can result in a permanent loss of market share for the late entrant (Urban et al. 1986) and thus lower future cash-flows. In literature, such a loss of is often ascribed to first-mover advantages, such as lock-in effects.

## 2.5 Delayed entry and first-mover advantages

Competitive dynamics in a projects target market play an important role in determining how to value a delay option. Several studies have attempted to clarify the potential impact on a project's outcome, when a delay option is exercised, and entry is delayed. Notably, Weeds (2002) studied the relationship between the strategic interaction of firms in a winner-takes-all patent system and their level of R&D investment.

The authors constructed a game-theoretic model in which R&D investment is dependent on competitor actions as firms take sequential steps in determining their R&D activities depending on rival's actions. The authors argue that according to real options theory a higher uncertainty regarding investment outcome should slow down the investments of firms as delaying becomes more attractive. However, in a winner-takes-all patent system, where the first firm to file a patent receives all economic gains, fear of pre-emption should counteract this effect. The overall incentive to delay investments should, therefore, be low in such a competitive environment. They reason that the timing and speed of investments into R&D should be high in a winner-takes-all competitive environment.

Contrary to these expectations, the authors model shows that in such an environment competition can actually slow down R&D activities. If both firms are able to start their R&D investments simultaneously and actually do so, the individual firm returns are lower compared to when they choose to time their investments according to a leader-follower scheme. The authors argue these lower returns imply that in a winner-takes-all patent system, the fear of starting a patent war with an uncertain outcome increases the option value of delaying, thereby hindering R&D investment. (Weeds, 2002). This implies for managers that the value of delaying investments in innovation projects is contingent on the characteristics of the competitive environment they are operating in. However, Weeds (2002) results are derived out of a purely theoretical equilibrium model with the assumptions of symmetrical firms that have complete information, which limits practical the applicability of their findings.

Despite the limited practical applicability of some studies, overall the research suggests that a delay bears a cost due to the risk of competitors gaining first-mover advantages. Accounting for a potential loss of market share due to competitors' early entry seems to be especially relevant for radical innovation projects. These projects often target new markets which are subject to high amounts of environmental uncertainty. In such markets, first-mover advantages

can be significant and a later entry can be costly for the delaying firm (Suarez & Lanzolla, 2007). Our methodology will account for first-mover advantages by implementing a *loss to delay* parameter in the valuation. This parameter will operationalize the expected permanent loss of market share the late entrant incurs due to first-mover advantages competitors gain. Thereby, we should receive a more accurate valuation outcome and get a more realistic understanding of how delaying investments impacts a real-options valuation.

As mentioned by Suarez and Lanzolla (2007), environmental uncertainty is an important factor when it comes to determining the optimal market timing. To capture the value of a delay option accurately, we therefore also need to consider the uncertainty pertaining to a project and the option itself. In research, several studies have examined the relationship between environmental uncertainty, the option to delay investment and real options in general.

## **2.6 Uncertainty and Option Value**

Bloom and Van Reenen (2002) take a different perspective to research delay options, by looking at patenting citations done by over 200 British firms since 1968. In their study, the authors use patents as a proxy to measure firms innovation activities. They distinguish between a market value and a productivity effect patents have on firms. Patents represent new products or process innovations whose introduction, however, involves sizeable investments into firm capabilities, which are most often are irreversible (Bloom & Van Reenen, 2002). Their results suggest that patents directly convert into market value for firms but have a much slower effect on productivity. This lagging productivity effect is more pronounced in conditions of high market uncertainty. Bloom and Van Reenen attribute this to a real options reasoning in firms. In uncertain market conditions the value of not using a patent, and thereby not introducing the innovation it represents, becomes higher as the outcome is more likely to be unfavourable. A patent therefore gives firms the option to delay investments until uncertainty lowers. The study of Bloom and Van Reenen, therefore, shows a positive link between market uncertainty and the value of delaying investment when patents protect firms from competitive threats and subsequent losses to delay.

Another stream of literature has looked in more detail at the interplay between real options and uncertainty. Folta and O'Brien (2004) investigated the influence of industry uncertainty on the decision of incumbent firms whether to enter a new industry or not. Specifically, the study examined the tension between the option to delay investment, which discourages entry if

uncertainty is high, and the option to grow, which may encourage entry in the presence of uncertainty when there are first-mover advantages (Folta & O'Brien, 2004). The authors argue at different levels of uncertainty different options will dominate the entry decision of firms. Thereby, they imply that the options values of the option to delay and grow will vary in different ways with uncertainty. If a firm should enter a new market immediately to take better advantage of growth opportunities, or delay the entry, depends on the nature and size of the delay and growth options, whose value, in turn, depends on the uncertainty in the target industry. In their study, Folta and O'Brien (2004) refer to uncertainty as the volatility in potential cash flows gained by entering the target industry. This volatility is due to variations in demand for an industry's products. To approximate this measure, Folta and O'Brien use the total output an industry contributes to the overall US gross domestic product.

Their test is a model of firms in 51 industry groupings defined by Compustat SIC codes, that estimates how the investment policy to enter a new SIC business segment or not, varies with the volatility of returns in the target industry. The authors find that the decision to invest is related non-monotonic to industry uncertainty, decreasing up to the 95<sup>th</sup> percentile of industry volatility and only increasing after. Up to this percentile, higher industry-specific uncertainty thereby decreases the likelihood of entry. Thus, the value of the option to delay investment outweighs the option to grow for almost all levels of uncertainty and a firm's investment policy of choice is not to enter an industry. Hence, the option to delay investment is an important factor to consider when evaluating projects within a real options logic.

They also find evidence that the degree of irreversibility of investments increases the value of a delay option in regard to market entry. Further, the value of available growth opportunities and first-mover advantages magnify the value of growth options (Folta & O'Brien, 2004). For innovation projects, this implies that in market scenarios with uncertainty, the option to defer to wait for an investment is often worth more than to exercise a growth option and enter a market right away. This study interprets their finding as broad evidence that depending on volatility in the target market, the benefits associated with delay options could outweigh the value of first-mover advantages gained from entering the market as planned. In innovation projects with targeting highly volatile markets yet with low first-mover advantages, considering a delay might, therefore, be especially important.

Research suggests, that the findings of Folta and O'Brien (2004) on the higher benefit of delay options versus growth options under uncertainty also holds for innovation projects. Cottrell and Sick (2002) performed a case study on follower advantages in the context of innovation in several industries. They argue that managers tend to focus their attention too much on the perceived advantages of being a market pioneer, such as pre-emption of rivals, technological leadership or imposing switching costs on buyers (Cottrell & Sick, 2002). The authors examine the benefits of a real option to delay by looking at the advantages that accrue to a follower strategy, such as gaining from the resolution of market or technological uncertainty or avoiding technological discontinuities that would make the early investment obsolete. Yet, during the period of waiting for optimal conditions, firms experience an opportunity cost termed the "convenience value." Convenience value is the benefit foregone from not having the project in operation (Cottrell & Sick, 2002). In the context of new product development, this is the incremental contribution margin from new product sales that is missed. Compared to the earlier discussed loss to delay incurred from competitors, this concept relates more to the idea of opportunity costs. From the examined cases, Cottrell and Sick conclude that second-mover advantages in innovation projects tend to outweigh first-mover advantages, especially when uncertainty is high. This study, therefore, provides evidence, if not quantitative, that delay options in innovation projects are important and increase in value with rising uncertainty.

Overall, Cottrell and Sick (2002), Folta and O'Brien (2004) and Bloom and Van Reenen (2002) provide important implications for the value of delay options in different market scenarios. Specifically, that managers should be aware of the level of uncertainty, their project is subject to, specifically in regard to expected cash-flows, when applying a real options methodology. Further, first-mover advantages have to be considered in evaluating a delay option. The studies also find evidence that investment delays can create value when substantial uncertainty exists. However, neither of the studies considers how the option to delay can specifically create value in an innovation management setting, as they focus on a broad range of industries. While emphasizing the merits of real options, the studies do not contribute to practical project valuation methodologies.

## **2.7 Market and Technical Uncertainty**

The previously described studies mostly define uncertainty as variance in the expected returns a project will yield. Oriani and Sobrero (2008) performed a study that provides a more nuanced view of the relationship between uncertainty, projects and a real options logic. They construct a framework to determine how uncertainty affects the market valuation of firms research and

development investments. As part of this, they acknowledge that different kinds of uncertainty have a different effect on the valuation of these investments. They argue that an R&D investment creates a portfolio of options for a firm, whose underlying asset is the present value of cash flows that can be acquired through subsequent investments. The value of the options increases with the variety of the returns on this underlying asset since there is a right but no obligation to exercise them. (Oriani & Sobrero, 2008). Agreeing with previous research, they conclude that the volatility of expected returns is essential when evaluating projects with a real options logic. Compared to other studies, Oriano and Sobrero (2008) however ascribe this volatility in returns to different sources of uncertainty.

*Market uncertainty* relates to the variability of the expected level of demand for a firm's products, which is similar to the concept of uncertainty chosen by Folta and O'Brien (2004) in their study. This concept depends on environmental factors such as the overall economy, institutional factors and changes in customer preferences and cannot be influenced by a firm (Oriani & Sobrero, 2008).

*Technological uncertainty*, the authors argue, refers to the uncertainty which technology will emerge dominantly in an industry, as established technologies often compete with rival technologies. This uncertainty is increasing with the number of technologies available, as it becomes less clear which one will emerge dominantly. Oriano and Sobrero (2008) argue that firms faced with these types of uncertainty have different options to exercise.

Building upon Folta and O'Brien (2004) they hypothesize a u-shaped relationship between the valuation of R&D investments and market uncertainty. Further, they assume an inverse u-shaped relationship between the valuation of R&D investments and technical uncertainty. Using a hedonic model to evaluate the R&D capital of 290 manufacturing firms publicly traded in the UK they find evidence for the hypothesized relationships. Therefore, they advance that the distinction between market and technological uncertainty is relevant for the market valuation of R&D (Oriani & Sobrero, 2008). This finding is important to the here proposed research question in several ways. First, it provides reasoning to split up uncertainty into two constructs when applying a real options methodology to evaluate innovation projects. Second, the study finds initial evidence that a delay options value is increasing asymptotically in market and technological uncertainty. Whereby the maximal benefit a firm can expect from a delay is losing the amount of additional resources invested in an irreversible way (Folta & O'Brien,



2004). As they represent the most comprehensive measures of uncertainty in literature, the constructs proposed by Oriani and Sobrero (2008) are used for the model built within this study. However, compared to Oriani and Sobrero (2008) this research will measure a delay options value as part of a practically applicable valuation model that can be used in projects. This requires a different approach to conceptualizing and calculating the options value than most of the empirical research existing which is primarily theoretical in nature.

## **2.8 Industry-Specific Real Options Research**

As most of the real options research is theoretical, the practical applicability of its findings is still lacking. This has implications for the popularity of real options methods in firms. Hartmann and Hassan (2006) examine the application of real options in the pharmaceutical sector via a survey. They find that real options are used as an auxiliary tool within this sector, that is complementing traditional techniques. Yet the actual level of formal implementation is still low, due to the assumed complexity of the method (Hartmann & Hassan, 2006). While they partly attribute this to the fixation of decision-makers on the Black-Scholes-Merton model, lattice models also still lack attention (Hartmann & Hassan, 2006).

McGrath and Nerkar (2004) arrive at a similar conclusion in their study. They investigated R&D investment decisions in the pharmaceutical sector over 17 years if they are consistent with real options logic. Their findings suggest, that strategic decision-makers do either intuitively or explicitly use real-options reasoning when making investment choices under uncertainty (McGrath & Nerkar, 2004). Thereby, they provide evidence that despite all the merits of the real options method, the research has not translated into a lot of practical application.

To counteract this, the authors McGrath and MacMillan have tried to provide frameworks for decision makers to facilitate implementation of real-options methods. McGrath and MacMillan (2000) provide a method for assessing uncertainty technology projects through scoring a series of statements. A similar approach is taken again by MacMillan and McGrath (2002). However, the methods suggested by these authors are not built to actually value investment projects but only provide a framework to assess a projects relative attractiveness. Thereby these methods still lack practical applicability in project valuation.

## 2.9 Main findings

Existing literature agrees that the value of a delay option values depends on the specific characteristics of the industry a project is targeting. A reoccurring theme is that with rising market uncertainty, the value of a delay option increases. This relationship seems to be nonlinear if other options exist. However, no study presented in this review has attempted to actually examine the valuation impacts of including a delay option under market uncertainty on a project level of analysis. Further, current empirical research primarily investigates if firms act according to a real options reasoning in their past investments decisions. There is still a clear lack of valuation models for practitioners.

This research builds on the research done on the value of real options under market and technological uncertainty. Specifically, with regard to implementing these concepts in the valuation of radical innovation projects. In such projects, usually, several investments are made in sequential phases until the project reaches commercialisation. Existing valuation models do already incorporate abandonment options before commencing with the project at any stage (Copeland & Tufano, 2004; Van Den Ende, 2016).

While some studies have shown that a delay option can provide value to the option holder in situations of uncertainty, none of them has researched the impact of including such an option in multi-staged projects. All studies presented in this paper did only consider delay options in the context of single-staged project investments. Therein, delay options are only seen as a choice to the option holder before starting a project. Moreover, none of the studies on delay options did provide an actionable valuation model. Lastly, there are few papers which consider the costs that might be associated with exercising a delay. However, studies have shown that considering waiting costs is crucial for real-options based decision-making (Lewis et al., 2007). Our research will aim to bridge these gaps by providing an applicable valuation model that will be tested in the context of innovation projects considering costs associated with a delay.

## 2.8. Hypothesis

When evaluating delay options uncertainty plays an important role, as the options value derives from allowing firms to wait for environmental uncertainty to resolve (McDonald & Siegel, 1986). Research has categorized this uncertainty into market and technological uncertainty. As market uncertainty increases, we expect the value of a delay option to increase asymptotically as suggested by Folta and O'Brien (2004). In this research, we thereby expect, that in innovation projects with a high amount of market uncertainty, a delay option will exhibit a higher option value than in projects with lower uncertainties.

**Hypothesis 1: The value of a delay option in innovation projects will increase in market uncertainty.**

Further, we are interested in the overall relevance market uncertainty has in driving a delay options value. In line with our proposed research questions, we suppose that market uncertainty will have a stronger, moderating effect on this value than technical uncertainty.

**Hypothesis 2: The impact of market uncertainty on a delay options value is higher than the impact of technical uncertainty.**

As mentioned by Eschenbach et al. (2009) and Lewis et al. (2007), considering the cost of delay is fundamental to capturing a options value accurately. Our research will, therefore, implement a Loss to Delay parameter to account for possible costs of delaying an investment. This parameter will represent expected losses in market share from a late market entry. We assume this parameter to exhibit a negative impact on a delay options value, however, we assume the positive impact of market uncertainty to be stronger than it.

**Hypothesis 3: The impact of market uncertainty on a delay options value is higher than the impact costs to delaying have on the options value.**

Moreover, this research will look specifically at innovation projects with multi-staged investments. In such projects, several investments are made in sequential phases until the project reaches commercialisation. McDonald and Siegel (1986) argue that a delay options value arises from the chance that some uncertainty regarding an irreversible investment decision will clear as time passes by. Folta and O'Brien (2004) find that a delay options value should increase

the higher the degree of irreversibility in investments is. Oriani and Sobrero (2008) argue that the maximum value a delay option can provide is the amount of irreversible investment that can be delayed. Following these findings, a delay options value should increase with the total amount of irreversible investments that are outstanding until project completion after the options execution. Hence, we expect that a delay option should have an especially high value if the investment phases still outstanding after the delay make up the majority of a project's total required investment amount.

**Hypothesis 4: A delay option will show a higher value for projects in which the majority of the investment sum is committed subsequent to the delay.**

The investments in each phase of a project are seldom of equal size and thereby some phases bear the risk of a significantly higher loss in case of project failure than others. This risk can be conceptualized in terms of the probability the technological development of the project will fail or that the target market develops unfavourably after proceeding with the investment. If this risk is sufficiently high, current real options models might suggest abandoning a project than proceeding with it. While the risk regarding the technological realizability of the project won't change over time, we assume that uncertainty regarding the market can clear up. Using a delay option, we assume that a firm postpones the decision to invest and thereby can still proceed with the project if the market seems to develop more favourably after the delay period. This should capture incremental value in a project valuation compared to an abandonment option, as a firm still has the opportunity to seize potential future cash-flows after the investment delay.

To evaluate this incremental option value, we will compare the results of two real options models: *Model 1*, which is based on existing research by Copeland and Tufano (2004) and Van Den Ende (2016) and includes an abandonment option; and *Model 2*, which will be developed in the methods section and includes a delay option.

We will use the valuation difference between both models to measure if a delay option provides incremental value to the overall project valuation.

**Hypothesis 5: A Real options model with a delay option (Model 2), will yield a higher valuation than a real options model with an abandonment option (Model 1).**

Testing these hypotheses will provide insights into how a delay option impacts the valuation of a radical innovation project under different circumstances of uncertainty. Moreover, it will allow us to answer the proposed research questions in regard to the cost of delaying. This research will thereby provide practitioners and researchers with an intuition under which project circumstances delay options can yield high value and when they should be considered in determining a project's value.

## 3. METHODS

---

This chapter explains the methodological approach of this research in further detail. First, the reasons for choosing a case study approach as a primary research method are explained. Following, the data collection process of the collected cases is explained. Moreover, we outline the limitations of our research concerning the data used and discuss the reliability and validity of our results. Lastly, we describe the applied valuation methodologies and their theoretical background in additional detail.

### 3.1 Rationale for a Case Study Approach

This thesis will employ a qualitative study methodology with a sample of multiple cases that are both cross- and within-analysed. Dul and Hak (2008) define a case study as ‘a study in which (a) one case (single case study) or a small number of cases (comparative case study) in their real-life context are selected, and (b) scores obtained from these cases are analysed in a qualitative manner’. The unit of analysis of these cases will be real-life radical innovation projects performed by companies.

The suitability of this approach derives from multiple factors. First, the research question proposed by this study aims to explain *how* a delay option interacts with market uncertainty within a real options model and its final effect on innovation project valuation. According to Yin (2003), a qualitative study is suitable in cases where research is trying to answer “How” and “Why” questions. Moreover, this thesis will develop a real options model new to literature and apply it to value past innovation projects. It is, therefore, theory-building in nature. For research that is theory building, a case-study approach is well implementable (Eisenhardt, 2016). Designing this study as longitudinal, theory-building research using a “multiple-case” methodology yields several advantages as well as limitations.

Obtaining the data on investments projects that is needed for this research is difficult. Archival data often doesn’t provide all information needed, specifically in regard to market uncertainty of a project. Moreover, investment data of companies is highly confidential and seldom publicly available in the required depth. Lastly, several variables needed for this research are subject to managerial discretion and cannot be obtained from other sources. Hence, there is only limited data available to apply the real options model build in this research to.

Following a multiple case approach allowed for an initial testing of the developed real options model in an empirical context even with limited data. Thereby, allowing us to derive initial suggestions for practitioners as well as further research.

However, by using a case-based approach, the results specified in this research are also subject to limited generalizability depending on the population selection criteria (Creswell, 2013). If the results obtained are therefore valid for all kinds of radical innovation projects is questionable. External validity, and therefore generalizability, of a case-based approach, can be improved by selecting the population of cases precisely (Eisenhardt, 2016). To ensure reliable results, cases in the sample of this research were selected based on whether an investment delay would have been financially and technically feasible according to the interviewees.

### 3.2 Framework

The conceptual framework of this thesis draws on multiple constructs from literature to answer our research question, namely ‘Market Uncertainty’ and ‘Technical Uncertainty.’ Moreover, we constructed the cost of delaying investment with a ‘Loss to Delay’ parameter. Along with other variables, these constructs were used as input parameters for the two real options models used in this research. However, only the model with a delay option included the ‘Loss to Delay’ parameter. Figure 3 shows how we expect these

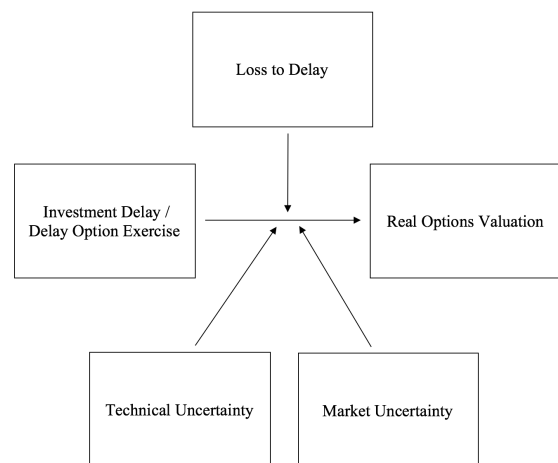

Figure 3: Framework for determining the impact of a delay option on a real options valuation

constructs to act as moderators that influence a delay options value and thereby the final real options valuation. Our dependent variable within this research was the real options valuation received from applying the two models which are described in section 3.7.

### 3.3 Data Collection and Analysis

In line with the proposed research question, cases on radical innovation projects in a range of industries were analysed, and the developed real options model applied to them. Thus, the unit of analysis of cases used in this study is radical innovation projects. The primary method of data collection in this research was semi-structured interviews with managers that had participated in an RSM class. As three variables used in this study, market and technical

uncertainty, and Loss to Delay, can only be obtained from managerial estimates another method data collection besides interviews was not feasible. Interviews were held freely except an outline that specified the case study parameters that needed to be collected. These parameters were the variables required to calculate an innovation projects value with the valuation methods compared in this study. For a complete list of these parameters refer to Figure 4.

Besides the application of valuation models, a sensitivity analysis between market uncertainty and the valuation of delay options within the cases was performed. This was done to control for possible variations in market uncertainty due to managerial misjudgement. By doing so, the valuation of radical innovation projects and the value of delay options could be approximated under different scenarios. Thereby ensuring, that results obtained in this research are robust towards subjective data in the collected case studies.

Moreover, we performed a sensitivity analysis on all input parameters and several Monte-Carlo simulations on a *hypothetical project* with the help of the @Risk software package from Palisade Corporation. This was done to analyse changes in the value of a delay option within our developed real options model under different circumstances of input parameters. Specifically, the Monte-Carlo simulation allowed us to vary input parameters according to a probability distribution and thereby find project situations in which delay options have high value.

### **3.4 Validity**

Every step that is taken to collect and analyse data has an impact on the validity and reliability of the results of this research. Yin (2003) identifies three forms of validity: construct validity, internal validity, and external validity. Internal validity is not applicable in this study because of the lack of causal relations between the used constructs. For this study, the construct validity and external validity of results are crucial, which will be discussed following.

Construct validity is concerned with the identification of correct operational measures for the studied concepts, as the phenomenon under study has to be defined in terms of certain concepts (Yin, 2003). This study aims to quantify the valuation impact of adding an option to delay investments within a real options logic. The concepts being used, namely market uncertainty, technical uncertainty, loss to delay, a delay option and a real options approach are based on findings within the literature review. However, as shown in section 3.7 Valuation Models3.7



Valuation, a real options valuation has to be based on some form of mathematical model that determines the valuation outcome. This is also true for the valuation of delay options.

The construct validity of this research hinges on the correct selection of an appropriate measure for market uncertainty and the loss to delay. To maximize construct validity, we based our valuation on a special form of the binomial tree, that has been used by past research in real options, to model market uncertainty. However, as discussed later, there are several shortcomings of the used trinomial model in accurately modelling market uncertainty. Moreover, the loss to delay parameter was modelled according to a suggestion by Eschenbach et al. (2009) that is not explored so far in research. The developed real options model is therefore exploratory. The above arguments limit the construct validity of this research.

External validity refers to the degree to which the results from a case study can be generalised (Yin, 2003). In a multiple-case study approach, the replicability of results supports external validity. Our process of data analysis aims to ensure that the results derived from analysing the cases within this research can be replicated with other samples of radical innovation projects. We base our calculations on a widely used trinomial lattice model in its general form. Thereby, the developed methodology can easily be applied to a multitude of cases from which further results can be derived.

### **3.5 Reliability**

With the concept of reliability Yin (2003) refers to the question of whether another researcher would generate the same results repeating the study of this thesis. First, all steps of data collection and selection are clearly described. Further, the performed calculations are transparent as they are based on widely known mathematical models. Using the same methodology and parameters on the same sample would let a researcher derive the same valuation outcomes. Therefore, the reliability of our results is high.

### **3.6 Limitations**

This study is researching the influence of delaying investment under market uncertainty within a real options valuation. Based on existing research, we propose that adding a delay option is beneficial for the overall valuation of the project and subsequent investment decisions based on real options reasoning. However, the data collected are past cases of radical innovation projects for which no actual delay has occurred. Thereby, we cannot make definitive statements what

the actual cost of waiting would have been had the delay occurred during the actual project. Instead, the proposed valuation methodology will provide an estimate for this cost based on a model parameter. Further, no definitive statements can be made if decisions derived from our model would have been optimal, as the estimated delay options value are also only estimations. If a definitive improvement in the form of a more precise project valuation, would have occurred can therefore not be determined ex-ante after the project completion.

### **3.7 Valuation Models**

The research objective of this study is to establish the effects of using a real options model with a delay option on a radical innovations project valuation. To draw conclusions, this real options model needs to be compared to a real options model with only an abandonment option. Following, the valuation models employed in this study will be discussed.

In relation to methodology, the study is an analysis of archival data as data from already existing innovation projects is used. This gives us the opportunity to evaluate each project in both an abandonment-option and a delay-option model. Thereby, the added value of a delay-option can be examined in different scenarios. Moreover, the influence of market uncertainty on the valuation of a delay-option can be examined across projects.

To assess the differences in valuation, two valuation models will be used, that use market and technical uncertainty as measurements of risk. Both options models are based on a so-called “trinomial lattice”. Through such a lattice, projects that require several sequential investments can be evaluated under market and technical uncertainty.

The two valuation models differ only in the option that is included as an alternative to each of the sequential investments, in case the option value of the investment is zero. The models will herein be called *Model 1* and *Model 2*. Model 1 assumes the project will be abandoned in case of an option value of zero. Model 2 assumes in this case that the investment, and thereby the projects commercialization, is delayed by one year. Therefore, Model 2 substitutes the abandonment option for a delay option while relying on the same trinomial lattice. This substitution will enable us to capture the valuation impact of adding delay options in a real options calculation. For the sake of providing a comparison to traditional valuation methods, a Net Present Value calculation is applied to each project as well.

## Valuation parameters

The valuation models discussed in this section are using a hypothetical project with the parameters shown in Figure 4 for explanatory purposes. It is important to note that not all parameters presented, are used for all valuation models. Instead, each model only uses some specific parameters. Before discussing the specific valuation methodologies in more detail, the different input parameters are briefly explained.

Project Data*	
Project Duration	3 Years
# Lattice Steps	3 Steps
Market Value High (p*)	55,00 € (5%)
Market Value (p*)	30,00 € (25%)
Market Value Low (p*)	0,00 € (70%)
Delay Loss / Year	25%
Risk Free Interest Rate (ann.)	0,5%

Invest Cost per Phase*	
Phase 1 (Present Value)	1,000 € (1,00 €)
Phase 2 (Present Value)	3,000 € (2,99 €)
Phase 3 (Present Value)	12,000 € (11,88 €)

\*Euros in Millions

Demand Volatility	
Sigma	0,43

Technical Success	
Phase 1	60%
Phase 2	60%
Phase 3	90%

Trinomial Tree	
$\Delta t$	1,00
$u$	1,84
$m$	1,00
$d$	0,54
$P_{up}$	18,37%
$P_m$	48,98%
$P_{down}$	32,65%

Figure 4: Parameters of project used for explanation purposes

**Project Duration:** The amount of time a project will need until product development is finished and the target market can be entered. Market entry is assumed to immediately follow the completion of R&D activities.

**Number of Lattice Steps:** To model real options in a trinomial lattice, we need to determine how many time steps it will contain. While the project duration determines the time span the lattice underlying our model encompasses, the number of steps determines how many time intervals this span is split into. The project in Figure 4 could, for example, be split up into six steps of half a year each or three steps with a length of one year each. In this research, the number of steps will equal the project duration in years, as each step is assumed to be one year in length.

*Investment Cost:* To evaluate the projects with a real options methodology, investments are assumed to be sequential and made over several points in time. The investment cost per phase represents the cost of each of these sequential investments. All investment costs are discounted by a risk-free interest rate calculated on an annual basis.

*Market Value:* Once all investments in the project have been done the innovation is supposed to generate revenues in the marketplace. The Market Value represents the expected earnings a project will generate after launch and depends on the market demand for the introduced innovation at the time of commercialisation. However, the future market demand for a product is difficult to estimate. For calculating the Net Present Value three market value scenarios (high, low and average), including their probabilities of occurring, are created.

*Risk Free Rate:* This is the theoretical interested rate that could be gained by investing into an asset with zero risk. This rate is used to discount the investment cost and the option values in the trinomial lattice. A risk-free rate of 0,5% is assumed for all valuations in this research.

*Delay Loss / Year:* As mentioned by Eschenbach et al. (2009) most literature fails to consider that a delay in a project is often associated with a drop in the expected commercialisation values. This can, for example, be due to competitor's actions, such as an earlier market entry with a competing product and subsequently a permanent loss of market share, or changes in the regulatory environment (Eschenbach et al., 2009). This '*Loss to Delay*' will be modelled through a percentage discount '*l*' to the projects final market values if an investment is delayed.

*Sigma / Market Uncertainty:* This parameter is used to model market uncertainty in the trinomial lattice. As the market demand for a product can move up or down over time, we define market uncertainty as '*the uncertainty on the future development of an innovation products market demand*'. Following Oriani and Sobrero (2008), market uncertainty can be operationalized as the degree to which demand for an industries products diverges from the level of demand that could have been expected. Market uncertainty, therefore, is the deviation of the future market demand for a product. In a trinomial lattice, the volatility *Sigma* represents the degree of variation in a financial assets expected future value. Since this concept is similar to our Market Uncertainty construct, we can operationalize the later as *Sigma* ( $\sigma$ ) in the trinomial lattice, similar to the approach Copeland and Tufano (2004) used for a binomial lattice.

## The Net Present Value Approach:

A basic NPV-approach will be used to evaluate each project. In this calculation, the initial investment is taken in year 0 and investments in subsequent years are discounted by a risk-free rate. For simplicity, we assume that the expected market values at the time of commercialization are already discounted. Discounting is not only an essential part of an NPV calculation but also necessary to make the values comparable to valuation outcomes of real options models in which discounting is used as well. To make the valuation outcomes of all applied valuation models comparable, it is necessary to assume the same discount rate for the NPV and real options calculations.

For calculating the NPV, the expected market values in the year of commercialization are estimated as well as the probabilities of realizing each scenario. What can be seen in Figure 5 is that these market value scenarios are € 55 Million, € 30 Million and €0. Their probabilities are 5%, 15%, and 80% respectively. As mentioned before, these market values are assumed to be discounted already.

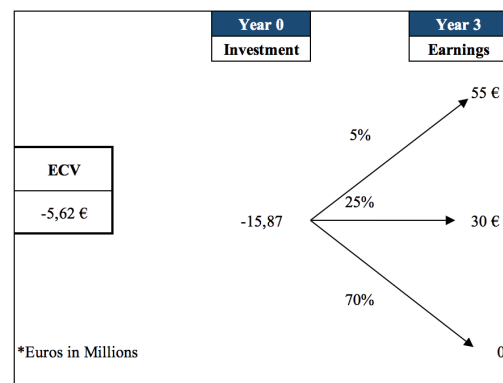

Figure 5: NPV Calculation Logic

To calculate the NPV, the cumulative discounted investment costs must be subtracted from the discounted expected earnings multiplied by their scenario probabilities.

$$NPV = (0,05 * 55 + 0,25 * 30 + 0,7 * 0) - 15,87 = -5,62$$

In this example, the resulting NPV is (-) €5,62 Million, which means that an NPV calculation would suggest not to start the project.

This negative valuation results from the fact that an NPV calculation cannot take into account the “optionality” of investments. Instead, all investments are assumed to be done no matter the expectable final market outcome. Further, there is no dissemination of the individual scenario probabilities into their technical or market uncertainty components. As such, an NPV calculation with scenario probabilities closely resembles an expected value calculation. However, it cannot capture the possibilities of a real options calculation to make different managerial decisions depending on how a project’s development proceeds.

Thereby, it cannot account for the opportunity to delay or abandon a project if circumstances turn unfavorable over time. These contingencies can be modelled within a real options approach that is based on a trinomial lattice. Following, the concept of a trinomial lattice is explained and its application in real options valuation. Specifically, we discuss some of the limitations when applying such a lattice in real options valuation. Moreover, we explain how to derive the value of a delay and an abandonment option in such a lattice.

### Real Options Valuation in a Trinomial Lattice

To capture the value of the option to abandon or delay the project in case the market develops unfavorably, or the technical development fails, we model the project in a trinomial lattice. Lattices exist of nodes and edges that connect them and are used to simulate price movements of an asset over time. In a lattice the time-period until an asset matures is divided into time steps of equal length. Applied to the valuation of innovation projects, the term ‘asset’ would hereby refer to the ‘Market Value’ of the innovation at hand. The maturity of an asset would coincide with the duration of a project. Using lattices, we can model the movement of the market value of an innovation over time. The most-simple lattice-based model is the binomial lattice proposed by Cox et al. (1979), where the price of an asset can go up or down each period. A trinomial lattice is an extension to the binomial lattice and was first proposed by Boyle (1986). In a trinomial lattice, the asset price can either go up, down or stay the same with each step in the lattice tree. Compared to the binomial model, where market values can only go either up or down each step, a trinomial model, therefore, allows for modelling an additional market movement.

This method is chosen for evaluating real options in this research, as it enables us to model the different ways a market can develop with more freedom than in a simple binomial lattice. Different authors have proposed different computational models for building trinomial lattices that can value different option types, such as barrier options (Ritchken, 1995).

The specific trinomial lattice used in this research, is a recombining trinomial tree in general form. In such a recombining tree, the factors by which the market goes up or down stay constant with each step. This means that if the market values go up in one period and down in the next, the movements will cancel each other out, resulting in the original value. As the lattice is used to model the movement of market values, and thereby also market demand, over time we will call the resulting option tree a ‘*Market Tree*’.

A figure of a recombinant trinomial market tree can be seen in Figure 6. For this research the model parameters are calculated according to Clifford and Zaboronski (2008), which present a general form trinomial model, building on the Cox-Ross-Rubinstein binomial method.

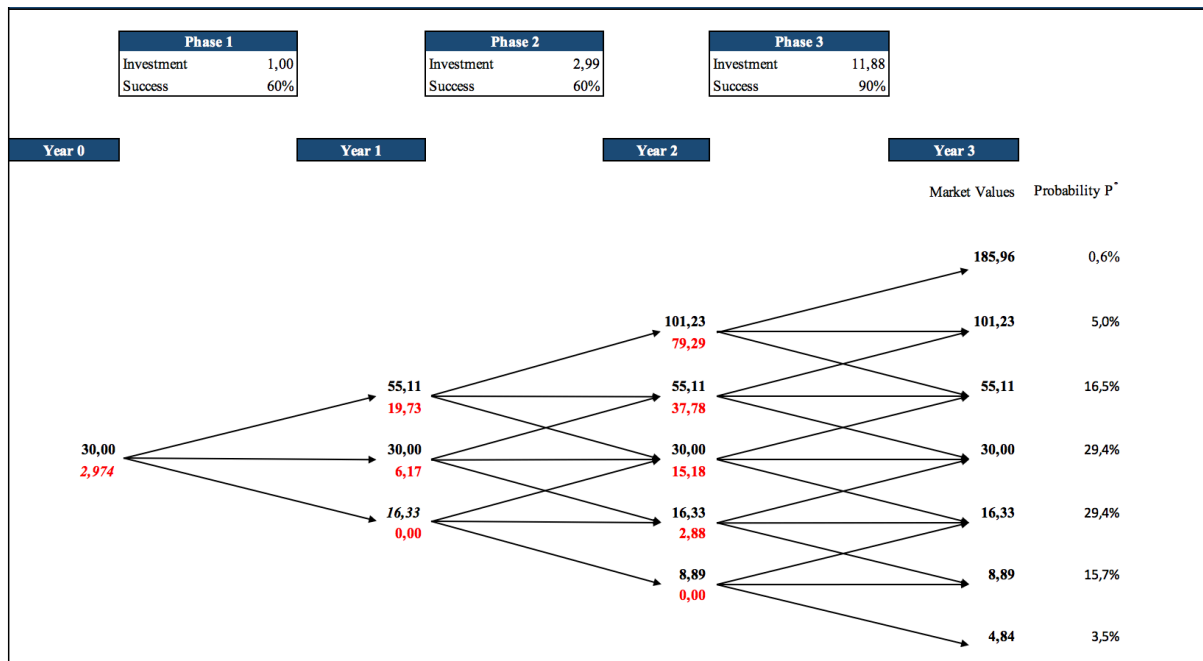

Figure 6: Example of a Trinomial Market Value Tree

### Constructing a Trinomial Market Tree

To construct the trinomial market tree, this research leans on the method introduced by Copeland and Tufano (2004) for evaluating real options in a binomial tree. Since a trinomial tree is merely an extension of a binomial tree, this method can be applied to a trinomial model.

The first step is to estimate the market value at time point  $T = 0$ . In this research, the market value at  $T = 0$  will be the average expected market value at the time of commercialization. After determining the initial market value, the *up*, *down* and *maintain* factors need to be estimated. These factors are calculated based on the estimated market uncertainty *Sigma*. This uncertainty represents the variability for the market demand for a certain innovation to grow or shrink over time. Following the method of Copeland and Tufano (2004), the variability of market returns of an innovation is assumed to be following a standard normal distribution. As a result, the jump sizes for up movements in a trinomial model can be determined according to the following formula (Clifford & Zaboronski, 2008):

$$u = e^{\sigma\sqrt{2\Delta t}}$$

In the above equation,  $e$  represents the base of the natural logarithm,  $\sigma$  is the market uncertainty and  $\Delta t$  the time interval size a jump movement covers ( $\Delta t$  is always set to 1 in this research). For every model based on the Cox-Ross-Rubinstein binomial method, the down-factor is set to be the inverse of the up-factor. Thereby the tree becomes recombinant:

$$d = e^{-\sigma\sqrt{2\Delta t}} = \frac{1}{u}$$

The value of a maintain movement is assumed to be one, which means the expected market returns do not change over time if a maintain movement occurs.

$$m = 1$$

Based on these jump factors, the values of the subsequent steps in the market tree can be calculated by multiplying each of the market values with these factors. For each time step in the market tree, the number of terminal nodes increases by two, as visible in Figure 6. The higher the number of time steps modelled, the higher will, therefore, the dispersion of the final market values be. From Figure 6 it can also be seen that in every year there is a possibility of moving from one expected return value to one of three others via one of the jump factors. The likelihood of realizing the up, down or maintain jump factor can be calculated from the formulas provided by Clifford and Zaboronski (2008):

$$\text{Probability Up Movement: } P_u = \left( \frac{e^{(r-q)\Delta t/2} - e^{-\sigma\sqrt{\frac{\Delta t}{2}}}}{e^{\sigma\sqrt{\frac{\Delta t}{2}}} - e^{-\sigma\sqrt{\frac{\Delta t}{2}}}} \right)^2$$

$$\text{Probability Down Movement: } P_d = \left( \frac{e^{\sigma\sqrt{\frac{\Delta t}{2}}} - e^{(r-q)\Delta t/2}}{e^{\sigma\sqrt{\frac{\Delta t}{2}}} - e^{-\sigma\sqrt{\frac{\Delta t}{2}}}} \right)^2$$

$$\text{Probability Maintain Movement: } P_m = 1 - P_d - P_u$$

It is important to note that these formulas were constructed for evaluating financial options. Therefore, they include the dividend yields  $q$  of an underlying stock. Since assets underlying



real option such as new technologies, machinery or intellectual property, are not financial assets they do not yield dividends. For calculating real options, we ignore  $q$  by assuming it to 0%.

### *Fitting a Market Tree to an NPV-calculation*

A disadvantage of using a general form trinomial lattice to model the market value development is that the dispersion of the final market values tends to include extreme values. Making the rightmost nodes of the lattice resemble the scenario estimations of NPV calculations is difficult. This difficulty arises from the assumption of lattice-based models, that the market values and their realization probabilities follow a lognormal distribution (Hull, 2015). However, scenarios for an NPV calculation, do not necessarily follow a lognormal probability distribution but can resemble any distribution chosen by the practitioner (Haahtela & Haahtela, 2006). Lattice-based real options models, therefore, cannot mirror the scenarios of an NPV-approach exactly. This is independent of the number of modelled jump movements, as this problem will occur with binomial, trinomial and any other sort of multinomial model (Kamrad & Ritchken, 1991). We, therefore, need to ensure a fit between the scenarios of an NPV-calculation and the market values of a trinomial tree by estimating an appropriate value for sigma.

### *Estimating Sigma*

The last step in constructing the market tree is to estimate the market uncertainty Sigma. To find a sensible estimate for this parameter, we iteratively change Sigma until the final market values have a distribution that approximately fits the NPV-scenarios.

By looking at Figure 7, it is apparent that there is a total of seven final market values, compared to only three market value scenarios in the NPV calculation. The total market value of these seven scenarios is 492,36 compared to a total sum of 85,00 from the scenarios used in the NPV-calculation. To avoid a systematic over or undervaluation of a project from a real options method, the *total expected value* of both the market tree and the NPV scenarios should match closely. Thereby, Sigma must be determined in a way that ensures this.

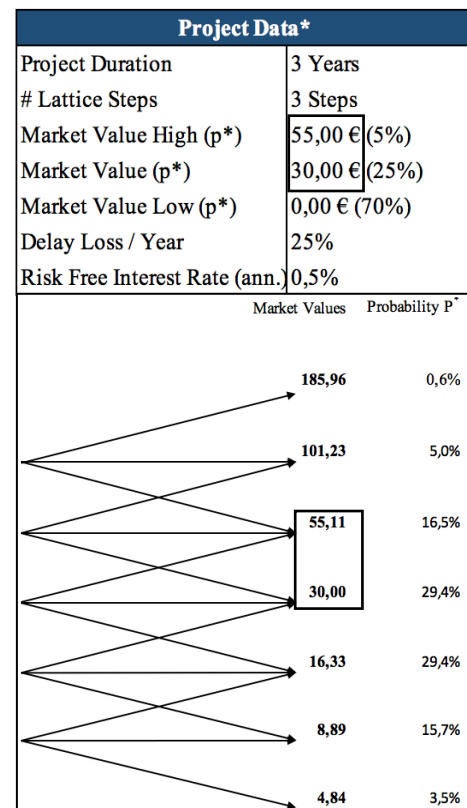

Figure 7: Distribution of final market values in the lattice compared to the NPV scenarios.

For comparing the total expected value of the market tree to the NPV-scenarios, we first adjust the probabilities of each NPV-scenario to include only market uncertainty. The reason for this step is that the probabilities in the NPV market value scenarios include both a technical and a market uncertainty component. To remove the technical uncertainty from these probabilities, we first calculate the *total chance of technical failure* by multiplying the chance of technical failure in each phase of the project.

In our example from Figure 4 this would yield a value of  $(60\% * 60\% * 90\%) = 68\%$ . We then subtract this number from the lowest market value scenario of 70%. The probabilities of the NPV scenario probabilities excluding technical uncertainty are then 5%, 25% and 2% as visible in Table 1.

The last step in adjusting the probabilities is to divide each of them by the total sum of  $5\% + 25\% + 2\%$ , resulting in the ‘P\* Adjusted’ values visible in Table 1. By multiplying these adjusted probabilities with the market value of the NPV-calculation, we receive the sum of 31,64 for the total expected value of all estimated market scenarios.

Market Value Scenario	P* incl. Technical Uncertainty	Chance of Technical Failure	P* excl. Technical Uncertainty	P* Adjusted
High	5%	68%	5%	15,4%
Medium	25%		25%	77,2%
Low	70%		2%	7,4%

Total Expected Market Values					
NPV Scenario			Trinomial Lattice with $\sigma = 0,43$		
Scenario Value	P* Adjusted	Exp. Value	Scenario Value	Probability	Exp. Value
55,00	15,4%	8,49	185,96	0,6%	1,15
30,00	77,2%	23,15	101,23	5,0%	5,02
0,00	7,4%	0,00	55,11	16,5%	9,11
			30,00	29,4%	8,81
			16,33	29,4%	4,80
			8,89	15,7%	1,39
			4,84	3,5%	0,17
<b>Total Expected Value</b>		<b>31,64</b>	<b>Total Expected Value</b>		<b>30,45</b>

Table 1: Total expected final market values in an NPV-calculation versus a trinomial lattice.

To choose the appropriate Sigma for the project seen in Figure 4, we change the parameter until the market value above the average value matches the highest NPV-scenario closely. An example of this can be seen in Figure 7. In our hypothetical project, this matching is achieved when setting Sigma to 0,43. Taking the data from Figure 4 with the determined Sigma of 0,43, a risk-free rate of 0,5% and  $\Delta t$  of 1, the resulting jump factors are:  $u = 1,84$ ,  $d = 0,54$  and  $m = 1$ . The rounded jump probabilities are  $P_u = 0,184$ ,  $P_d = 0,327$  and  $P_m = 0,49$ . This results in the market tree visible in Figure 6

If the terminal market values of the market tree from Figure 6 are multiplied by the probability of realizing each of them, which is depicted in Table 1, we receive a total expected value of 30,45. Thereby, we conclude that from iteratively changing Sigma until the node above the average matches the highest NPV-scenario, we receive a close fit of the NPV-scenarios and the real options market tree.

### Calculating the Option Values

After constructing the market tree and have determined Sigma, we can calculate the option values by working backwards from the terminal market tree nodes. For the penultimate period (Year 2) we do this by multiplying the final market values in Year 3 with the respective jump probabilities. Further, we need to account for any potential investment phases that would be required to even reach these market values. Finally, we discount the resulting option values with our assumed risk-free interest rate of 0,5%. Based on this the highest option value in Year 2 is then:

$$Option\ Value = \left( ( (185,96 * 0,1837 + 101,23 * 0,4898 + 55,11 * 0,3265) * 0,9 ) - 11,88 \right) * e^{-(0,005)} = 79,29$$

For the prior nodes in the tree, such as for Year 1, we follow the same calculation logic except for one difference. Instead of multiplying the possible market values in the next year with their respective probabilities, we multiply the option values pertaining to these market values. The highest option value in Year 1 is then:

$$Option\ Value = \left( ( (79,29 * 0,1837 + 37,78 * 0,4898 + 15,18 * 0,3265) * 0,6 ) - 2,99 \right) * e^{-(0,005)} = 19,73$$

The general form expression for calculating option values at any given node  $j$  is:

$$C_{t,j} = \left( \left( [p_u C_{t+1,j+1} + p_m C_{t+1,j} + p_d C_{t+1,j-1}] * P_{I,t} \right) - I_t \right) * e^{-r}$$

*Equation 2: General Form Expression for Calculation of Option Values in a trinomial lattice.*

$t$  represents a point in time (e.g. Year 2) and  $j$  a point in space,  $I_t$  represents the investment required to proceed to the next phase and  $P_{I,t}$  is the chance that the project technical development in this phase succeeds.

To make the options values in this research comparable, we derive some assumptions on the risk-free rate. First, a hypothetical, annual risk-free rate of 0,5% is assumed across all cases in this research to make the valuation outcomes comparable. This is necessary since the risk-free rate can impact the real options valuation in a trinomial model significantly by directly impacting both the option values via discounting and the jump factors as visible on page 32.

Further, the project phases in the analysed cases are all estimated to take one year to complete. This simplification has the advantage, that investment costs can be discounted by only using an annual risk-free interest instead of having to calculate periodic rates for different phase durations. Another implication of assuming that all phases require one year to complete is that  $\Delta t = 1$  for all analysed projects due to the following equation:

$$\Delta t = \frac{\text{Project Duration } N \text{ in Years}}{\text{Number of Steps in Tree}}$$

In the case of a project which has three phases, of which each requires a year to complete, our tree will have three steps and  $\Delta t = 1$ . Through setting  $\Delta t = 1$  and  $r = 0,5\%$  across all cases, we make the trinomial lattices comparable in terms of  $\sigma$  which represents market uncertainty. This can be seen from the equations for the movement factors and jump sizes.

After discussing the application of a trinomial lattice in a real options valuation and its limitations, the following section will explain how we derive the value of delay and abandonment options within such a lattice. Figure 8 describes the logic we use in our real options approaches in case the option values at any node in year 3 of a hypothetical project are above or below zero.

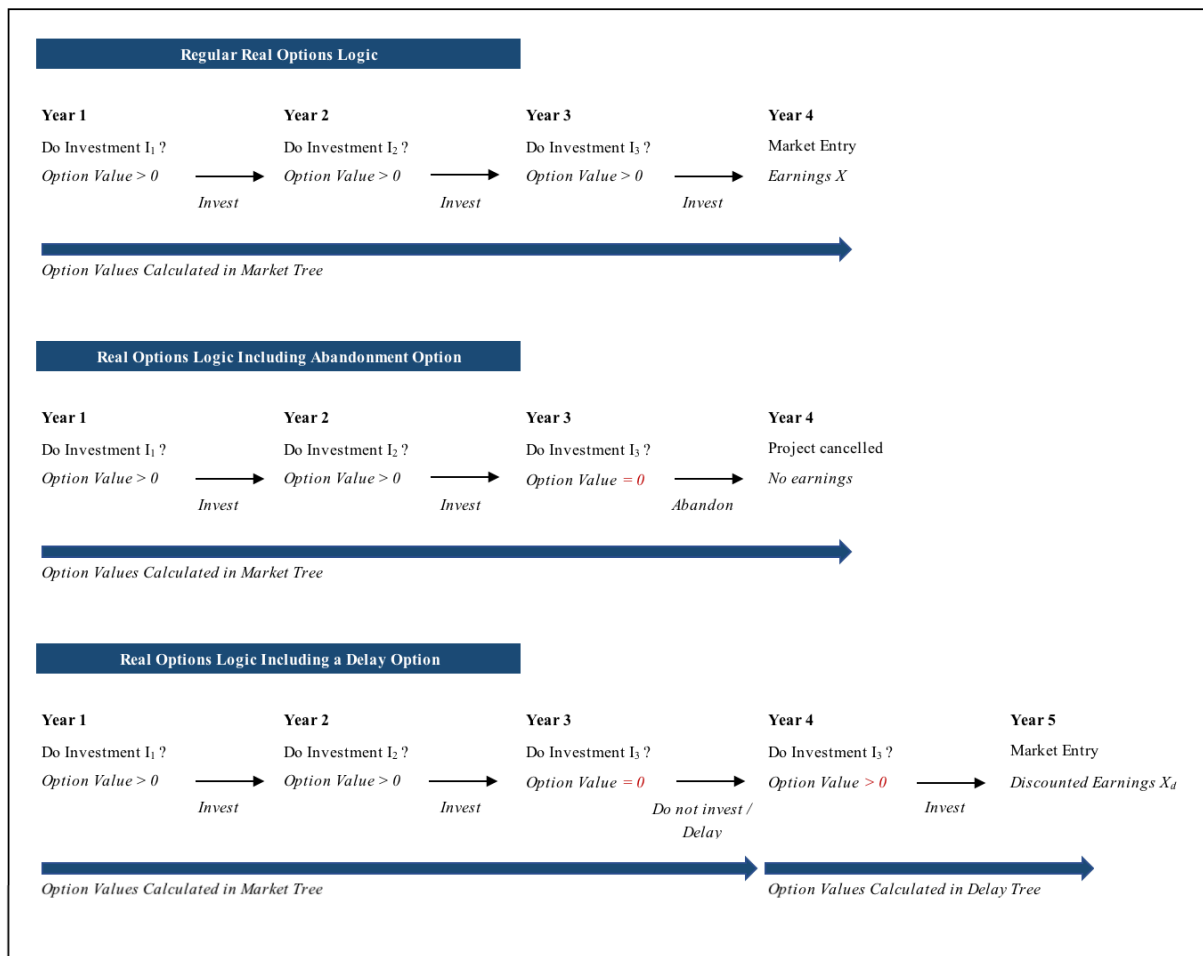

Figure 8: Different Real Options Logics in case of a negative Option Value.

In both our model including an abandonment option, as well as our model including a delay option, we assume that a sequential investment is always made in case of a positive option value at any node. However, if the option value in a year, such as year 3 in the figure, is negative, the logic is different. In case of an abandonment option, the project is abandoned, no further investment is made, and no earnings are generated from the project. In the case of modelling a delay option, we postpone the decision to invest by one year. Through postponing the decision to invest, such as from year 3 to year 4 in our example, we might realize a more favourable market scenario and therefore higher commercialisation values in the future.

Next, we will describe how we calculate both the option value of abandoning the project within Model 1 and the option value of delaying an investment within Model 2.

### *Model 1: Calculating an Abandonment Option in a Trinomial Lattice*

The boundary condition applied to the option values is that option values have to be nonnegative, meaning 0 is their lowest possible value. The reasoning behind this is, that a negative option value at any given node would imply that the investment costs to finish the project are higher than the expected future returns. However, this would imply to proceed with a project for which the Return-On-Investment given current market conditions is negative. We assume that in case the option value at a given node is negative, the project would be abandoned or delayed. The option to abandon can simply be modelled by substituting any negative calculation result gained for the option values for '0', as in case of abandonment no further value is received from the project. In this research, we will call the options model using this abandonment logic *Model 1*.

### *Model 2: Calculating a Delay Option in a Trinomial Lattice*

This research aims to analyse the valuation impact of adding a delay option in a real options model. Therefore, a modification to the regular trinomial model is done, so that a delay options value can be calculated. The delay option is added in the market tree, as it might be possible to achieve higher initial market returns by delaying the commercialisation of the project. This logic follows Copeland and Tufano (2004), which model a binomial tree in with a period where managers only wait for the market to develop in any direction.

We add the option by implementing a boundary value of 0 to the option values at all nodes as mentioned already for Model 1. However, as visible in Figure 9, instead of abandoning the project outright at this node, we calculate an alternative option value for this node assuming the decision whether to invest or not is delayed by one year. To derive the value of this delay option, we construct an additional market tree based on the same trinomial lattice parameters as the original tree. We call this tree a *delay tree*. The underlying logic of this tree is to model all possible future market scenarios, that can develop onwards from the node we choose to delay an investment at.

To construct the tree, we follow the steps shown in Figure 9. The most important step is to identify at which nodes in the original market tree a delay option will be calculated for. In any lattice, multiple nodes can have an option value of zero. An example of this can be seen in Figure 9, with option values of zero at the market values of 16,33 and 8,89. However, not for all of these two nodes, we will also model a delay option.

To avoid complex computations, we limit the number of investment delays within a project to one. This means that in only one period of the project a delay is possible. If the delay is done at the node of 16,33 in Year 1, no further delay at the 8,89 node is possible in Year 2. For constructing the delay tree, this implies that we have to identify the first point in time at which an investment would be delayed. In the tree in Figure 9, we will accordingly construct a delay tree from the node with a market value of 16,33 as it precedes the node of 8,89.

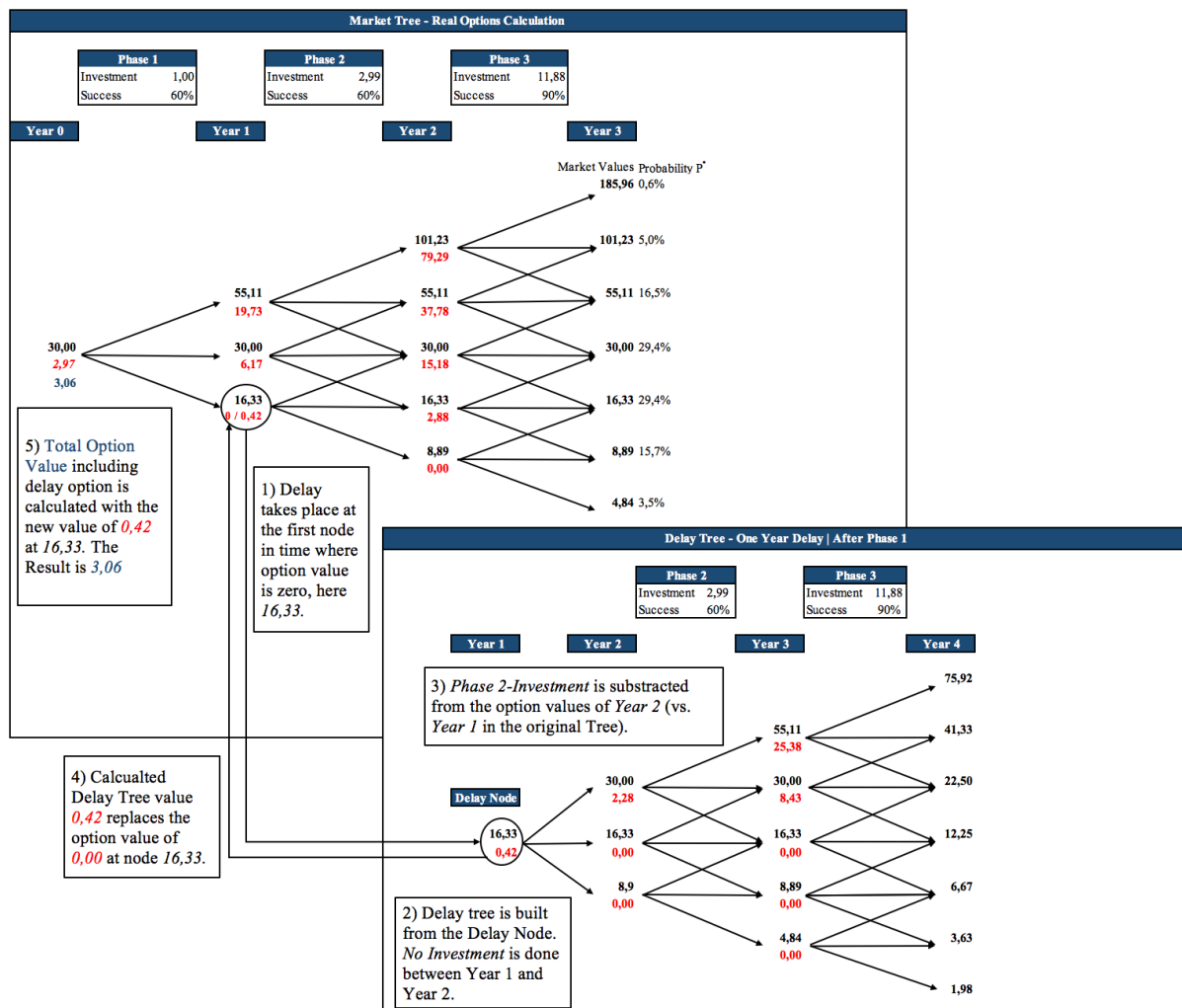

Figure 9: Graphical Illustration of the Delay Option Calculation Procedure in Model 2.

After choosing the node, we model a delay tree from this point in time onwards. The number of tree steps in the delay tree will be the number of steps left until commercialisation in the market tree plus one extra step to account for the investment delay. In our example, we would model the tree from Year 1 until Year 4. We include the fourth year, as delaying an investment in Year 1 would also delay the project completion by one year. The resulting delay tree can be seen in Figure 9.

The next step is to account for potentially lower market values in the delay tree in Year 4. As mentioned by Eschenbach et al. (2009), delaying a product's commercialisation can cause a company to incur costs, such as a reduction in the returns received once a project is in the market due to loss of market share to faster-entering competitors. Further, other external factors such as institutional or environmental changes can decrease the earnings potential of a delayed project (Eschenbach et al., 2009). Logically, such costs would reduce the expected earnings of an innovation in the market. Hence, we lower all market values of the final step of the delay tree by the size of the loss to delay parameter. In Figure 4 we assumed a loss to delay of 25%. This means we take the original market values of all nodes in Year 4 and multiply them by a factor of  $(1-l)$  where  $l$  is 25%.

Before calculating the option values at each node, we need to adjust when the investments are done, starting from the investment that was delayed. In Figure 9, the decision to invest in Phase 2 is delayed by one year. This means that the investment cost of 2,99 has to be included in the option value calculation of Year 2 instead of Year 1 in the original market tree. The same applies to the investment cost of Phase 3, which is included in the option values in Year 3. The procedure for calculating the option values follows the same formulas as for the market tree.

The option value at the initial node in the delay tree can be calculated by working iteratively backwards just as in any lattice-based real options calculation. The option value at the initial node represents the option value of delaying an investment at this node. It is the value of the delay option. In Figure 9 this is 0,42 Million Euros, which means that taking a delay option in case the market volume drops from 30 to 16,33 Million Euros in Year 1 would be preferable over abandonment and worth 0,42 Million Euros.

#### *Integrating a Delay Option in the Market Tree*

The last step in calculating the Model 2 valuation is to include the delay options value in the original real options calculation. Therefore, we replace the option value of zero at the node where the investment is delayed, with the option value of 0,42 from the delay tree. In the calculation in Figure 9 the delay option value of 0,42 replaces the value of zero at the node of 16,33. Moreover, as the original option value at the delay node was zero, our final market tree valuation is higher. The final result is a valuation of 3,06 Million Euros from Model 2 compared to 2,97 Million Euros from Model 1, excluding a delay option. In our hypothetical project, the delay option, therefore, captured additional value in the project valuation.



## 4. RESULTS

---

In this section, the results of this study are discussed as per the following order. First, we collected five cases, in which we applied an NPV-approach as well as real options Models 1 and 2 to real innovation projects. Second, we ran a sensitivity analysis on the impact of Market Uncertainty on a Delay options value for each of the five cases. Moreover, we performed a sensitivity analysis of all input parameters of Model 2 on the value of a delay option in different circumstances. Third and last, we ran several Monte-Carlo simulations to determine sets of input parameters for which Model 1 would yield a commercial value of zero while Model 2 would yield a positive value. Thereby, we tried to identify projects contingencies for which including delay options is important in order to avoid taking non-optimal investment decisions.

Next, we will first discuss the valuation results of each case study individually and afterwards look at all cases in comparison to draw potential conclusions relating to our research questions. As the projects contain confidential information, company names, product names and the names of interviewees to which the cases apply are not disclosed. The first case is discussed in additional detail to provide transparency on the applied methodology. The values of all financial parameters have been converted into units of million euros for ease of discussion and graphical illustration.

## Case 1: Offshore Oil-Drilling Technology for Salmon Farming

The first case analysed is a radical innovation in the food production industry. The innovating company intends to apply technology from offshore oil-rig platforms to salmon farming basins. Current salmon farming technology is only suited for breeding in the shallow waters of fjords. Yet new regulations are being worked on, particularly in Scandinavia, that will prohibit the use of farming basins in fjords from 2022 onwards. The innovation will offer salmon farming companies the ability to move their production offshore to cope with these new regulations.

Case 1: Additional Details	
<b>Nature of Innovation:</b>	The project is radical as the company plans to be the first to market in offering offshore solutions for salmon breeding.
<b>Technical Uncertainty:</b>	<ul style="list-style-type: none"> <li>- Combination of salmon breeding and offshore oil-rig technology turns out not to be technically feasible.</li> <li>- Oil-rig stabilization technologies are not able to provide stable salmon farming conditions.</li> </ul> <p><i>Conclusion:</i> There is significant uncertainty in regard to the technical feasibility of the project. This leads to high uncertainty, especially in the first phase. Overall this is a complex project, and the technical uncertainty is very high.</p>
<b>Market Uncertainty:</b>	<ul style="list-style-type: none"> <li>- Modifying oil-rig technology for salmon breeding cannot be protected by IP and could also be done by multiple competitors in the oil rig industry.</li> <li>- The market demand for this solution is dependent on government regulation that prohibits fjord breeding. If these regulations are adopted faster or slower than expected demand could deviate highly from expectations.</li> </ul> <p><i>Conclusion:</i> There is significant uncertainty as to the development of the market volume as well as the intensity of competition.</p>
<b>Uncertainty Indicator:</b>	<p><i>Chance of technical failure: 78%</i>  <i>Market Uncertainty/Sigma: 0,37</i></p>
<b>Expected Loss to Delay:</b>	<ul style="list-style-type: none"> <li>- Once multiple companies enter the market, competition is expected to shift towards competing on price. Therefore, big first-mover advantages exist.</li> </ul> <p><i>Expected loss of market value in case of late entry: 30%</i></p>

Table 2: Additional Information Case 1.

Before making the valuation, all relevant project parameters had to be determined or gathered. An overview of these parameters can be seen in Figure 10. The project data reveals that the total investment cost is €122 million. Discounting the investments per phase by 0,5% for one, two or respectively three years lead to a total discounted investment cost of €120,09 million.

Project Data*	
Project Duration	3 Years
# Lattice Steps	3 Steps
Market Value High (p*)	250,00 € (5%)
Market Value (p*)	150,00 € (15%)
Market Value Low (p*)	0,00 € (80%)
Delay Loss / Year	35%
Risk Free Interest Rate (ann.)	0,5%

Invest Cost per Phase*	
Phase 1 (Present Value)	5,00 € (5,00 €)
Phase 2 (Present Value)	12,00 € (11,94 €)
Phase 3 (Present Value)	105,00 € (103,96 €)

\*Euros in Millions

Demand Volatility	
Sigma	0,37

Technical Success	
Phase 1	35%
Phase 2	70%
Phase 3	90%

Trinomial Tree	
$\Delta t$	1,00
$u$	1,69
$m$	1,00
$d$	0,59
$P_{up}$	19,33%
$P_m$	49,27%
$P_{down}$	31,39%

Figure 10: Project Parameters Case 1.

The expected earnings for the first year in the best, average and worst-case scenario were assumed to be €250 million, €150 million, €0 respectively. From this the following NPV calculation was made:

$$NPV_{Case\ 1} = (0,05 * 250) + (0,15 * 150) + (0 * 0,8) - 120,09 = -85,89$$

A visualization of the NPV calculation with three scenarios can be seen in Figure 11. The calculation yielded a negative net present value of (-) €85,89 million, which implies that the innovation project should not be pursued.

However, NPV-calculations cannot consider the possibility to delay or abandon the project if technical development fails or the market develops unfavourably. On the contrary, an NPV-calculation assumes that all investments are carried out, even if the future market value of the project would turn out to be €0. Therefore, we used real options methods to capture the value of the project more precisely.

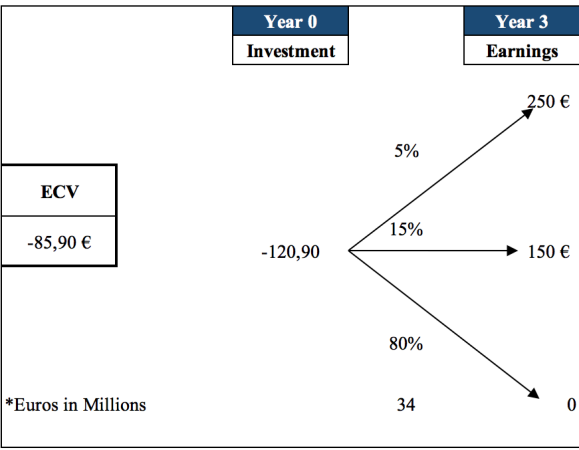

Figure 11: NPV Calculation Case 1

We applied the two real options methodologies from our methodology section to this case: Model 1, which only includes an option to abandon the project in case the option value is zero at any point in time; and Model 2, which includes the option to delay an investment instead of abandoning the project in case the option value at any point is zero. We based both of these methodologies on a market tree, as outlined in our methodology section. This allowed us to model different possible market values over time. Thereby, enabling us to capture the value of abandoning or delaying the project in case the expected market demand for the salmon farming innovation decreases sharply or the projects technical development fails. In general, the technical uncertainty of the project was very high, with a total chance of technical failure of  $1 - (0.35 * 0.7 * 0.9) = 78\%$ .

Next, we calculated the projects commercial value by using Model 1 and Model 2 respectively. Using the scenario of a €150 million market value as a starting point, we built a trinomial tree with three steps. As outlined in the methodology, we estimated *Sigma*, the market uncertainty, by iteratively adjusting it until the first node above the average market scenario in year 3 is close to the best-case NPV-scenario of €250 million. This was the case for a Sigma of 0,37.

After constructing the tree, we iteratively calculated the option values backwards including the investment cost at each phase. A visualization of the real options calculation with the market and delay tree for Model 1 and Model 2 respectively can be seen in Figure 12.

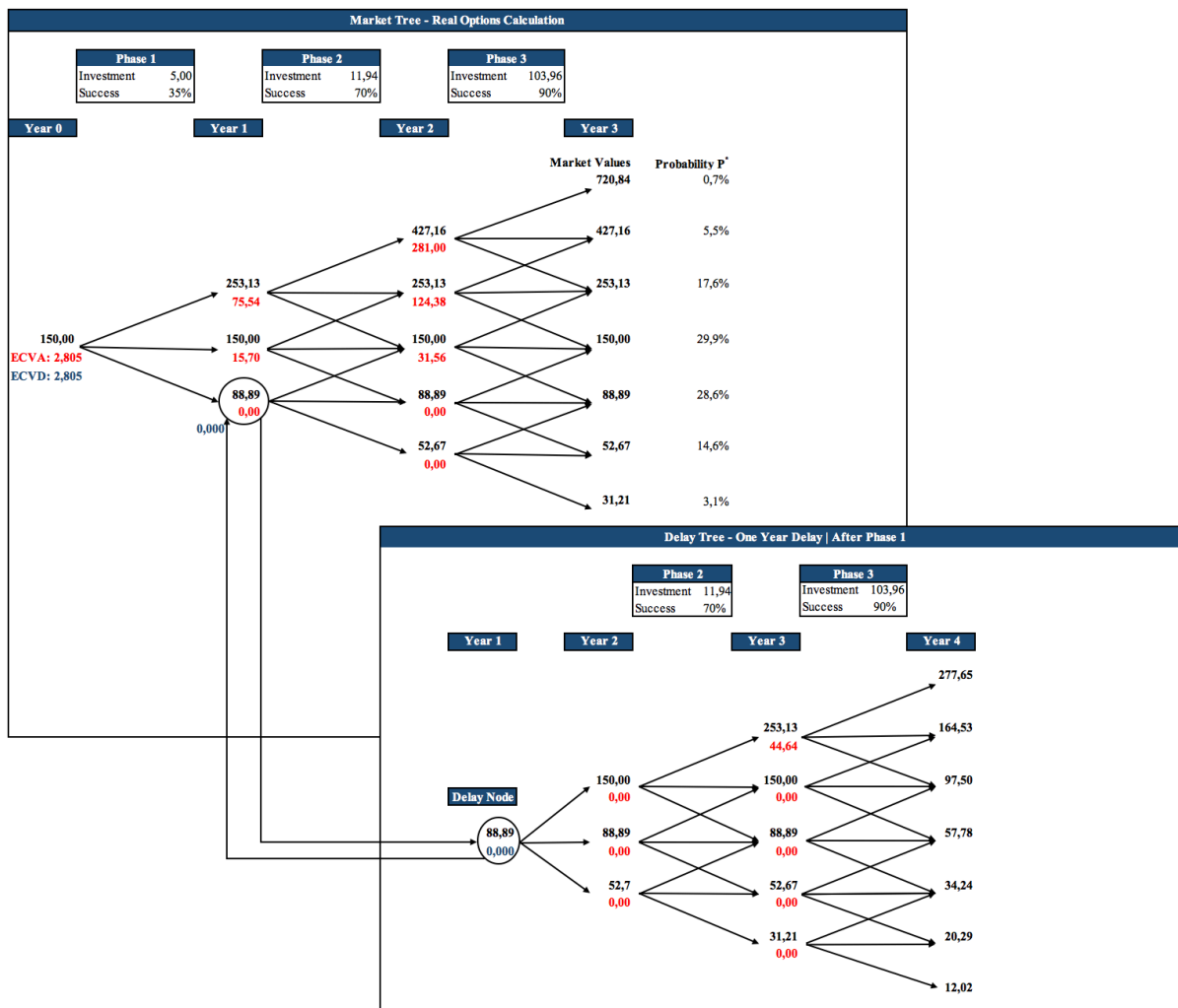

Figure 12: Visualization of the Market and Delay Tree for Case 1 for both Model 1 and Model 2.

As visible, the option value under a market scenario of 88,89 in Year 1 is 0. Based on Model 1, which includes the possibility to abandon, we would not continue with the project in case the market develops into this scenario. Using Model 2, we assumed that the investment of Phase 2 would instead be delayed by one year and built a delay tree starting from the node of 88,89. The delay trees market values in year 4 were reduced by a factor of 35%, as a permanent loss of market share is assumed if the market entry is postponed. The value of this delay tree, and thereby the delay option, was zero. ECVA and ECVD in Figure 12 denominate the valuation outcomes for both Model 1 and Model 2 respectively.

The final project valuation of Case 1 was € 2,805 million for both Model 1 and Model 2. This implies that following either real options model the project would be undertaken as the expected commercial value is positive. Moreover, it means that within our models we could not capture any additional value from delaying an investment and the delay options value was zero.

In Case 1 including a delay option, therefore, does not seem to yield any positive effect on the project valuation. However, both real options models based on a trinomial market tree result in a significantly higher valuation for the project than the NPV-calculation. This upside value arises from the possibility to abandon the investment. A summary of all visualization outcomes can be seen in Figure 13.

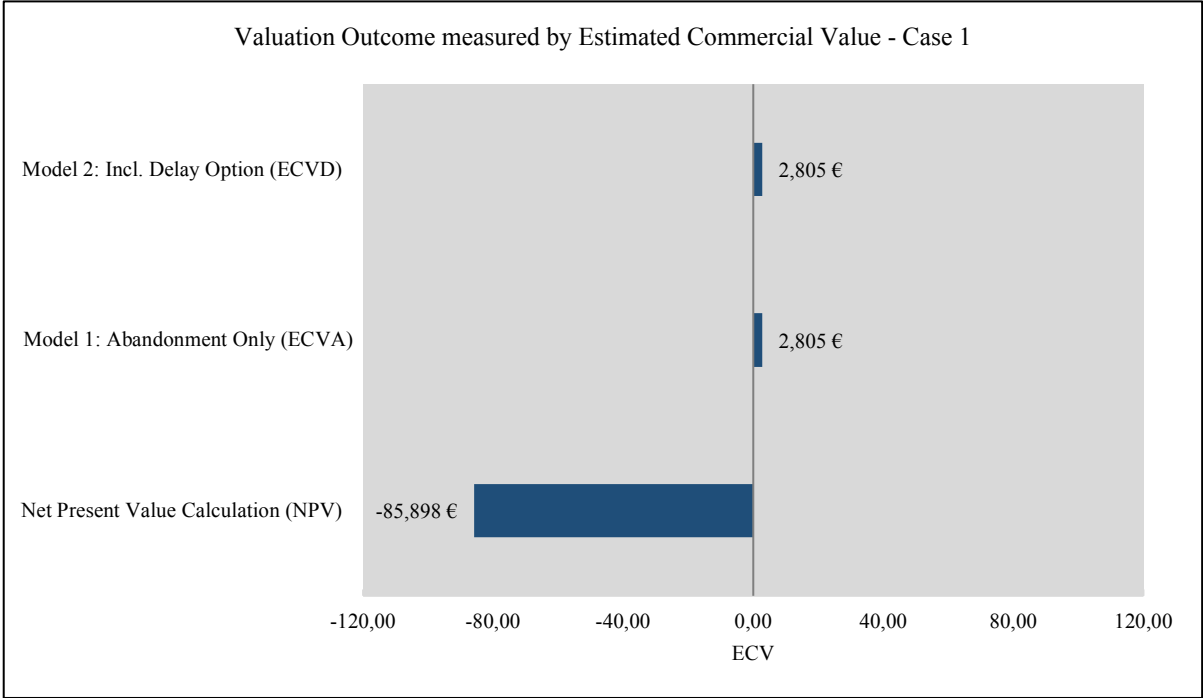

Figure 13: Valuation Outcomes Case 1. All Values in Million Euros.

## Case 2: Mobile Asphalt-Mixing Pontoon

The second case is a radical innovation in the construction sector. The innovating company intends to build a swimming asphalt-mixing platform for roadway construction. Currently, roadway construction relies on stationary asphalt-mixing platforms to procure materials, resulting in high transportation costs. Moreover, construction is significantly slower due to the transportation times required for the asphalt to arrive at the construction site. The radical innovation would make use of the Dutch waterways to solve this problem.

Case 2: Additional Details	
<b>Nature of Innovation:</b>	The project is radical as the company plans to be the first to offer a mobile asphalt-mixing installation.
<b>Technical Uncertainty:</b>	<ul style="list-style-type: none"> <li>- Adjustment of existing Asphalt-Mixing technology for use on water might not be possible.</li> <li>- Required Patents for bringing the innovation to market are not granted.</li> </ul> <p><i>Conclusion:</i> There is moderate uncertainty in regard to the technical feasibility of the project. After receiving the required patents and adjusting existing technology, the actual construction is only moderately difficult. Overall, this with a moderately high technical uncertainty.</p>
<b>Market Uncertainty:</b>	<ul style="list-style-type: none"> <li>- The technology underlying the asphalt-mixing platform is rather simple. The risk of imitation by competitors is high.</li> <li>- Competitors might enter the market with a cheaper technology before this product is introduced to the market.</li> <li>- Environmental regulations in relation to pollutants from fossil fuels could impact the demand for the platform.</li> </ul> <p><i>Conclusion:</i> There is significant uncertainty as to the development of the market volume as well as the intensity of competition.</p>
<b>Uncertainty Indicator:</b>	<p><i>Chance of technical failure: 54%</i>  <i>Market Uncertainty/Sigma: 0,55</i></p>
<b>Expected Loss to Delay:</b>	<ul style="list-style-type: none"> <li>- Once multiple companies enter the market, competition is expected to shift towards competing on price. Small first-mover advantages exist.</li> </ul> <p><i>Expected loss of market value in case of late entry: 10%</i></p>

Table 3: Additional Information Case 2.

Project Data*	
Project Duration	3 Years
# Lattice Steps	3 Steps
Market Value High (p*)	13,00 € (10%)
Market Value (p*)	6,00 € (30%)
Market Value Low (p*)	0,00 € (60%)
Delay Loss / Year	10%
Risk Free Interest Rate (ann.)	0,5%

Invest Cost per Phase*	
Phase 1 (Present Value)	0,70 € (0,70 €)
Phase 2 (Present Value)	1,40 € (1,39 €)
Phase 3 (Present Value)	2,90 € (2,87 €)

\*Euros in Millions

Demand Volatility	
Sigma	0,55

Technical Success	
Phase 1	60%
Phase 2	85%
Phase 3	90%

Trinomial Tree	
$\Delta t$	1,00
$u$	2,18
$m$	1,00
$d$	0,46
$P_{up}$	16,57%
$P_m$	48,27%
$P_{down}$	35,15%

Figure 14: Project Parameters Case 2.

We started the valuation as we did for Case 1 by performing an NPV calculation. The visualization can be found in Appendix A. The valuation parameters of this project can be found in Figure 14. Applying an NPV-calculation resulted in the following valuation:

$$NPV_{Case\ 2} = (13 * 0,1 + 6 * 0,3 + 0 * 0,6) - (0,7 + 1,39 + 2,87) = -1,864$$

The NPV-approach gave the project a negative commercial value of (-) €1,864 million. Therefore, it would not be undertaken.

Next, we applied the two real options approaches to Case 2. The visualization of the market and delay tree can be seen in Figure 15. We built the delay tree from the node of 2,76 as it had an option value of zero. The final market values in the delay tree were reduced by 10%. This resulted in the delay tree, and thus the delay option, yielding an option value of €0,085 million. Integrating this value back into the tree resulted in a final project valuation of €0,193 million using Model 2, compared to €0,175 million using Model 1. In both cases the projects commercial value is positive, and it would followingly be undertaken.



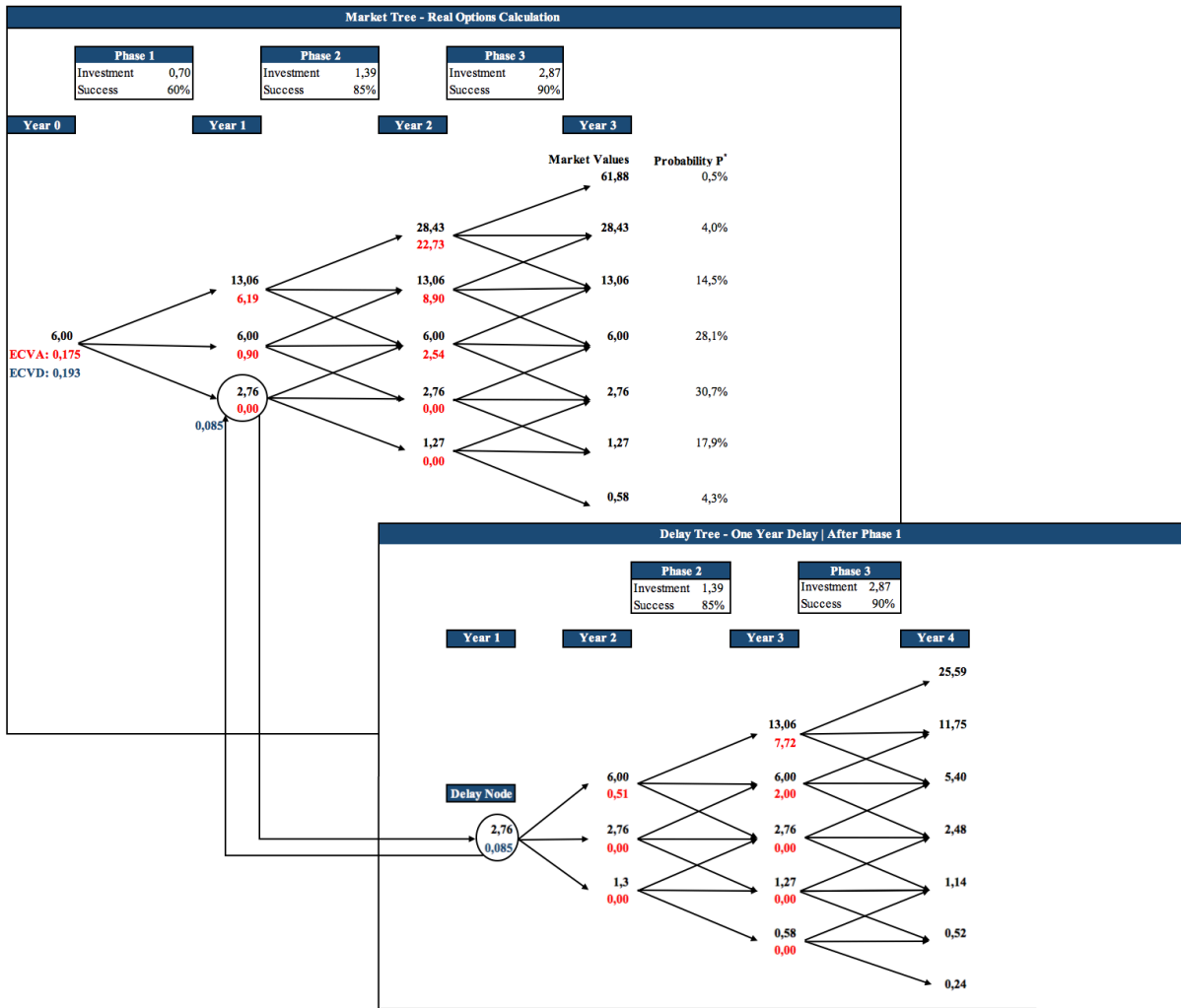

Figure 15: Visualization of the Market and Delay Tree for Case 2 for both Model 1 and Model 2.

In Case 2, including a delay option in the real options valuation did result in a higher commercial value of the project. Moreover, both real options valuations were higher than the NPV-valuation. As visible in the delay tree of Figure 15, the value of the delay option arises from the possibility that the market moves into a higher state in Year 2 and Year 3 up from the value of 2,76 in Year 1. The final project valuations using each of the three applied methods can be seen in Figure 16 to the right.

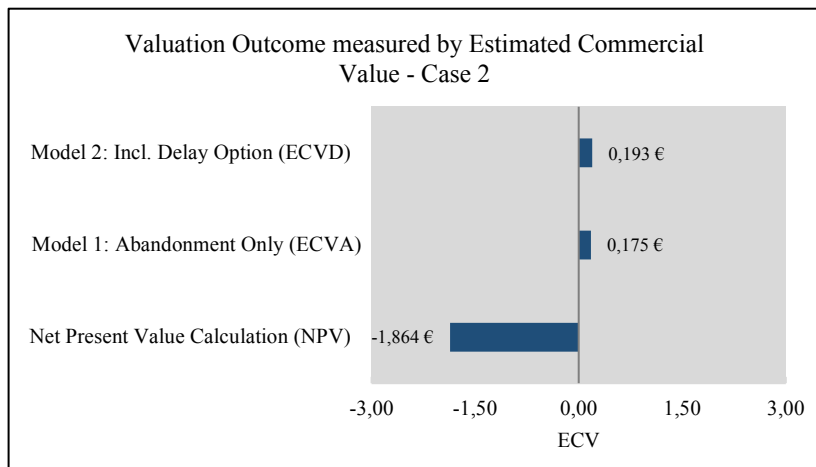

Figure 16: Valuation Outcomes Case 2. All Values in Million Euros.

### Case 3: Robotization of CNC Milling and Drilling Factory

Our third case study was a project that aims to automate the manufacturing of CNC parts with advanced manufacturing robots. The demand for CNC parts in the Dutch Market is projected to increase, but the growth in the manufacturing capacities of the CNC industry is outpacing demand. This lead to an oversupply in demand and pressure on prices. The innovating company hopes to gain a competitive edge over competitors by introducing automation into its factories which will lead to a more cost-efficient production.

Case 3: Additional Details	
<b>Nature of Innovation:</b>	The project is radical as the company plans to apply new robotics technology in CNC manufacturing.
<b>Technical Uncertainty:</b>	<ul style="list-style-type: none"> <li>- There might be an incompatibility of robots with existing production machinery.</li> <li>- Difficulty might arise in programming and setting up the robots to work seamlessly together.</li> </ul> <p><i>Conclusion:</i> There is high uncertainty in regard to the technical feasibility of the project. Specifically, the high complexity of adjusting the robots to work together with existing machinery leads to high technical uncertainty.</p>
<b>Market Uncertainty:</b>	<ul style="list-style-type: none"> <li>- The robot technology is bought from suppliers. The risk of competitors adopting similar technology is high.</li> <li>- The demand for products produced by robots is contingent on how cheaply competitors can produce CNC-parts.</li> </ul> <p><i>Conclusion:</i> There is a high uncertainty in regard to the possible usage of the robots as well as the intensity of competition.</p>
<b>Uncertainty Indicator:</b>	<p><i>Chance of technical failure: 64%</i>  <i>Market Uncertainty/Sigma: 0,49</i></p>
<b>Expected Loss to Delay:</b>	<ul style="list-style-type: none"> <li>- Competitors are likely to start introducing robot technology soon as well. In case of a delay, the company is therefore likely to lose some clients to competitors.</li> </ul> <p><i>Expected loss of market value in case of late entry: 15%</i></p>

Figure 17: Additional Information Case 3.

Project Data*	
Project Duration	3 Years
# Lattice Steps	3 Steps
Market Value High (p*)	4,57 € (5%)
Market Value (p*)	2,29 € (25%)
Market Value Low (p*)	0,00 € (70%)
Delay Loss / Year	15%
Risk Free Interest Rate (ann.)	0,5%

Demand Volatility	
Sigma	0,49

Technical Success	
Phase 1	50%
Phase 2	80%
Phase 3	90%

Invest Cost per Phase*	
Phase 1 (Present Value)	0,061 € (0,06 €)
Phase 2 (Present Value)	0,121 € (0,12 €)
Phase 3 (Present Value)	0,971 € (0,96 €)

Trinomial Tree	
$\Delta t$	1,00
$u$	2,00
$m$	1,00
$d$	0,50
$P_{up}$	17,45%
$P_m$	48,65%
$P_{down}$	33,90%

\*Euros in Millions

Figure 18: Project Parameters Case 3.

As for the previous cases we first calculated the NPV of Case 3. The visualization can be found in Appendix B. The project would again not be undertaken as the resulting estimated commercial value was (-) €0,343 million.

Next, we again built a market and a delay tree. The market uncertainty Sigma was estimated at 0,49. Compared to the previous case, there was no market scenario with an option value of zero in Year 1 but instead in Year 2. We, therefore, built the delay tree from the node of 0,57 in Year 2 and assumed a delay of the Phase 3 investment by one year. The final market values of the delay tree were reduced by 15%. As only one investment was left until the project could be commercialized, compared to two investments in Case 2, the delay tree was one step shorter. The resulting delay tree can be seen in Figure 19.

In Case 3 there was no additional value to be captured from delaying an investment as the delay tree had an option value of zero. Hence, the project valuations of Model 1 and Model 2 are identical. A real options approach yielded an estimated commercial value of €0,344 million for this case, which suggests contrary to the NPV-approach that the project should be undertaken. The valuation outcomes are summarized in Figure 20.

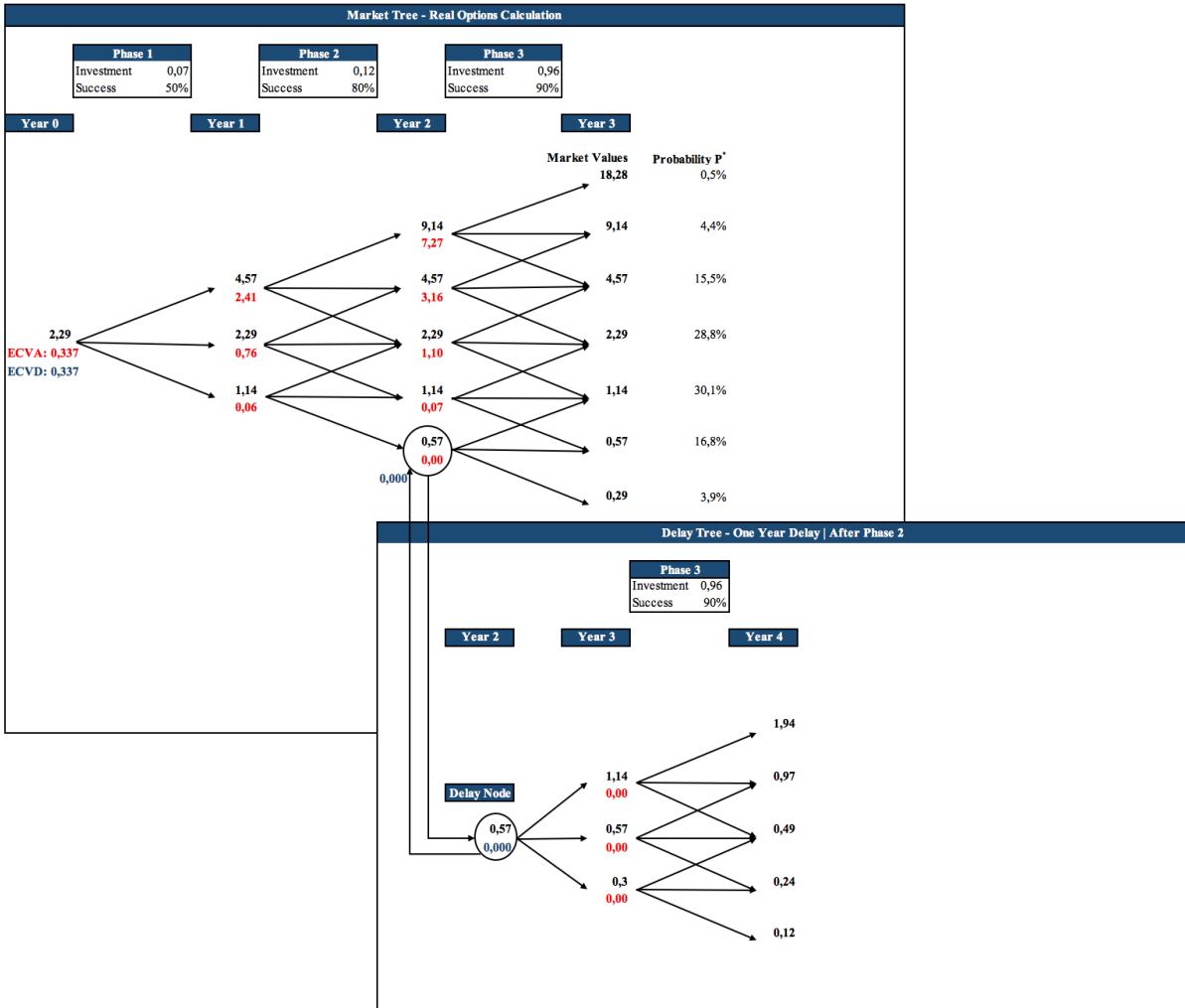

Figure 19: Visualization of the Market and Delay Tree for Case 3 for both Model 1 and Model 2.

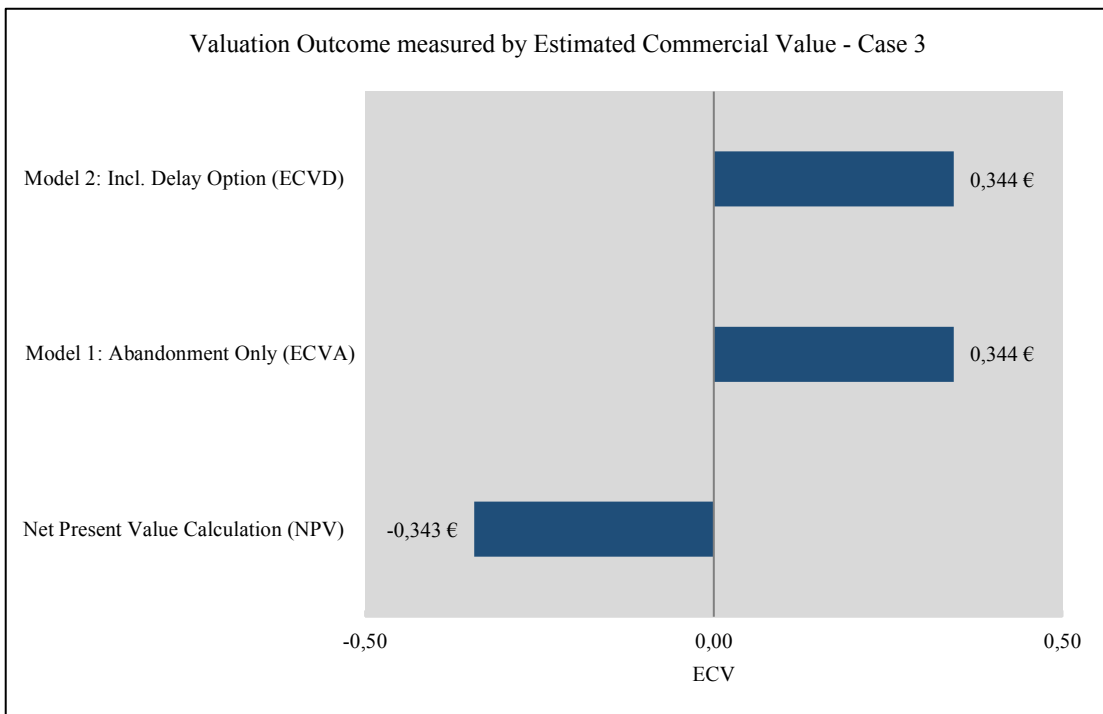

Figure 20: Valuation Outcomes Case 3. All Values in Million Euros.

#### Case 4: Print Publication for an Unserved Niche

Our fourth case was based on a print publishing product targeting a niche segment. While the overall market for print magazines is in decline, some niches still exist that show potential for growth. Specifically, the company aims to launch a magazine dedicated to content on old-timer cars of a German automobile brand. With the new print product, the company plans to gain readers who have a strong demand for content on this topic.

Case 4: Additional Details	
<b>Nature of Innovation:</b>	The Innovation is new to the market as the niche is unserved, while the underlying print technology is well-established.
<b>Technical Uncertainty:</b>	<ul style="list-style-type: none"> <li>- The automobile brand might refuse to grant the licensing rights to use its trademark in the magazine's title.</li> <li>- The third-party vendor determining the best distribution among the possible Points-of-Sale might make non-optimal conclusions in his analysis.</li> </ul> <p><i>Conclusion:</i> The overall technical uncertainty in this project is low. Notably, in Phase 2 the success chance is very high as the required technologies are well established.</p>
<b>Market Uncertainty:</b>	<ul style="list-style-type: none"> <li>- The publication might not gain readers in the potential target audience with as much traction as expected.</li> <li>- Advertisers could decide not to advertise in the new publication, resulting in a shortage of advertising revenue.</li> </ul> <p><i>Conclusion:</i> The market for print publications, and its niches, is matured and its development partially foreseeable. Market uncertainty mainly pertains to the product generating not enough demand from customers.</p>
<b>Uncertainty Indicator:</b>	<p><i>Chance of technical failure: 29%</i>  <i>Market uncertainty/Sigma: 0,23</i></p>
<b>Expected Loss to Delay:</b>	<ul style="list-style-type: none"> <li>- In the market for magazines, customers tend to develop loyalty towards a specific publication quickly. Thereby, very high first-mover advantages exist.</li> </ul> <p><i>Expected loss of market value in case of late entry: 40%</i></p>

Figure 21: Additional Information Case 4.

Project Data*	
Project Duration	3 Years
# Lattice Steps	3 Steps
Market Value High (p*)	345,00 € (20%)
Market Value (p*)	250,00 € (50%)
Market Value Low (p*)	0,00 € (30%)
Delay Loss / Year	40%
Risk Free Interest Rate (ann.)	0,5%

Invest Cost per Phase*	
Phase 1 (Present Value)	15,00 € (15,00 €)
Phase 2 (Present Value)	180,00 € (179,10 €)
Phase 3 (Present Value)	16,00 € (15,84 €)

\*Euros in Thousands

Demand Volatility	
Sigma	0,23

Technical Success	
Phase 1	90%
Phase 2	98%
Phase 3	80%

Trinomial Tree	
$\Delta t$	1,00
$u$	1,38
$m$	1,00
$d$	0,72
$P_{up}$	21,82%
$P_m$	49,78%
$P_{down}$	28,40%

Figure 22: Project Parameters Case 4.

In this case, an NPV-calculation yielded an estimated commercial value of (-) €15,946 million. As in all previous cases, the project would therefore not be undertaken when following an NPV-approach.

For Case 4 we built the delay tree from Year 1 as the market scenario of 180,58 had an option value of zero. The final market values in the delay tree were reduced by a factor of 40% as first-mover advantages in this project's target market are high. The market and delay tree are shown in Figure 23. As for Case 1 and Case 3, delaying an investment did not have any effect on the final project valuation as the delay tree had an option value of zero. Therefore, the project valuations from Model 1 and Model 2 were identical at €1,346 million. Compared to the NPV-approach this would suggest that the project should be undertaken. Like in Case 1 and Case 3, the higher real options valuation compared to the NPV-calculation also arose from the abandonment option, and not from including a delay option. The outcomes of all valuation methods are summarized in Figure 24.

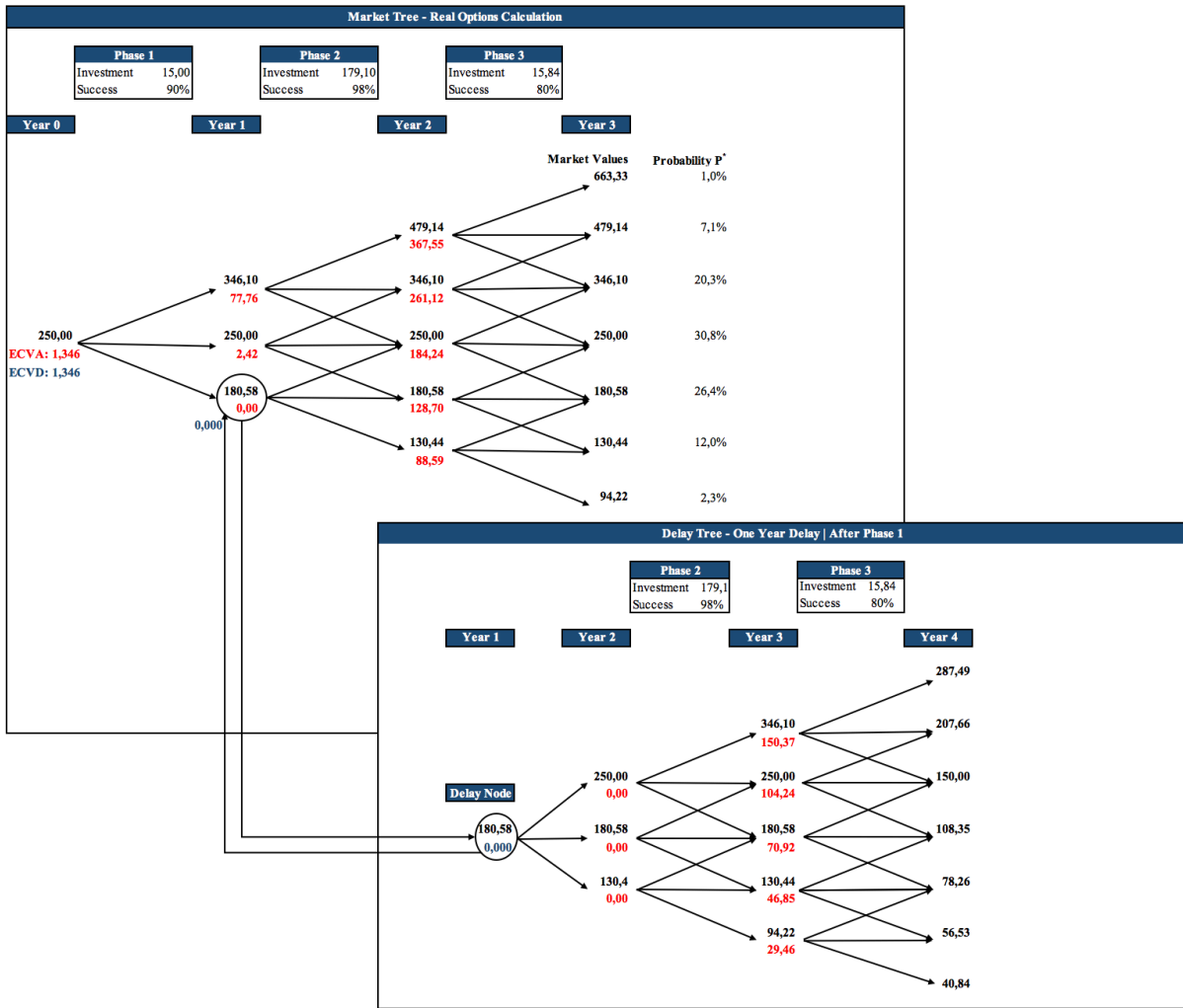

Figure 23: Visualization of the Market and Delay Tree for Case 4 for both Model 1 and Model 2.

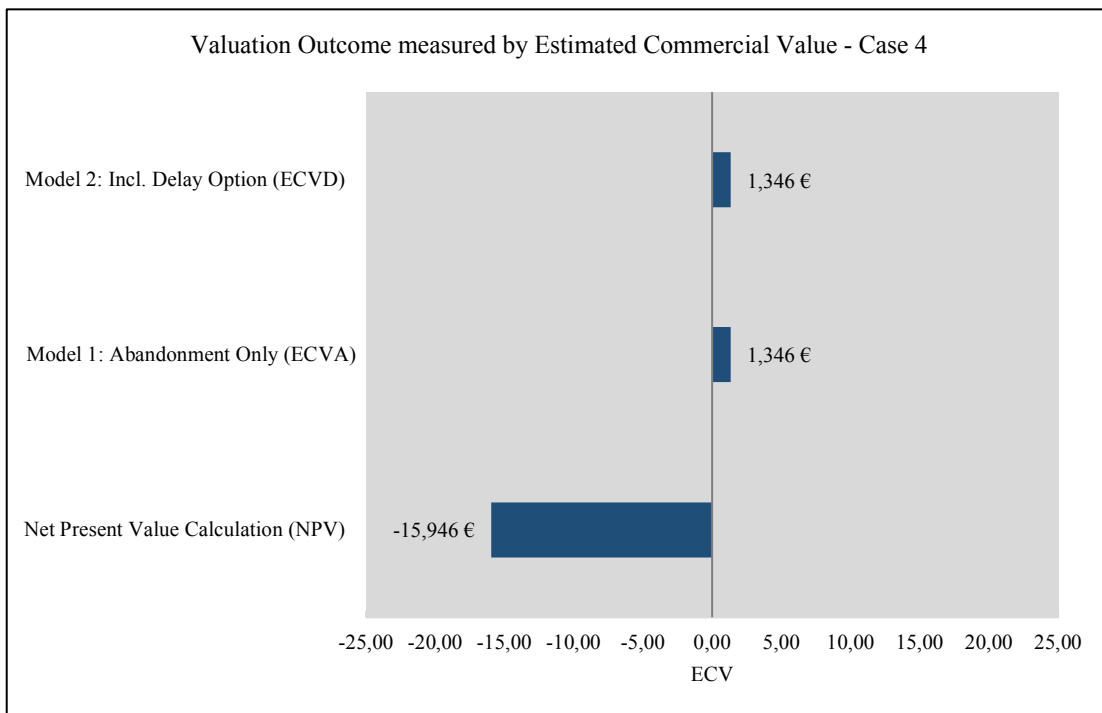

Figure 24: Valuation Outcomes Case 4. All values in Million Euros.

## Case 5: Web-Solution for Motorsports Image Licensing

The project aims to build a web-portal on which publishing professionals can license digital images of motorsports events from the 20<sup>th</sup>-century. While several companies exist that offer platforms for digital licensing of images none of them has an extensive archive of classic motorsports images. Moreover, these platforms take a cut of all licensing revenue for their services. The innovating company aims to combine its proprietary archive with modern web-technologies to create an own solution for offering its pictures, thereby addressing a gap in the market while avoiding the costs of using third-party licensing platforms.

Case 5: Additional Details	
<b>Nature of Innovation:</b>	The product is innovative as it targets an underserved market by developing a new technical solution for it.
<b>Technical Uncertainty:</b>	<ul style="list-style-type: none"> <li>- Implementing a user-friendly solution for exploring the archive efficiently could fail.</li> <li>- Legalities to ensure no copyright-infringements take place when licensing images might be too complex to implement on a small scale.</li> </ul> <p><i>Conclusion:</i> The technical uncertainty in this project is high as the portal needs to be developed at a low cost due to the limited market size, while high technical and legal uncertainties exist.</p>
<b>Market Uncertainty:</b>	<ul style="list-style-type: none"> <li>- The demand for the offered images is dependent on global interest in content on classic motorsports which is not estimable due to a lack of available data.</li> <li>- As images are licensed to professionals for use in publications, the content strategies of these motorsports publications influence demand for the images.</li> </ul> <p><i>Conclusion:</i> The market demand for classic motorsports images licenses is hard to estimate and dependent on multiple actors.</p>
<b>Uncertainty Indicator:</b>	<p><i>Chance of technical failure: 72%</i></p> <p><i>Market Uncertainty/Sigma: 0,32</i></p>
<b>Expected Loss to Delay:</b>	<ul style="list-style-type: none"> <li>- There are no substitute offerings for the archived pictures, threat from competitors entering earlier is not given.</li> </ul> <p><i>Expected loss of market value in case of late entry: 0%</i></p>

Figure 25: Additional Information Case 5.



Project Data*	
Project Duration	3 Years
# Lattice Steps	3 Steps
Market Value High (p*)	2,00 € (5%)
Market Value (p*)	1,30 € (20%)
Market Value Low (p*)	0,00 € (75%)
Delay Loss / Year	0%
Risk Free Interest Rate (ann.)	0,5%

Invest Cost per Phase*	
Phase 1 (Present Value)	0,10 € (0,10 €)
Phase 2 (Present Value)	0,20 € (0,20 €)
Phase 3 (Present Value)	0,45 € (0,45 €)

\*Euros in Millions

Demand Volatility	
Sigma	0,32

Technical Success	
Phase 1	55%
Phase 2	60%
Phase 3	85%

Trinomial Tree	
$\Delta t$	1,00
$u$	1,57
$m$	1,00
$d$	0,64
$P_{up}$	20,17%
$P_m$	49,48%
$P_{down}$	30,34%

Figure 26: Project Parameters Case 5.

For Case 5 an NPV-approach resulted in an estimated commercial value of (-) €0,385 million, implying that the innovation project should not be pursued.

Applying Model 1 resulted in an estimated commercial value of €0,019 million, with Sigma being set to 0,32. Based on the market tree of Model 1, we built a delay tree from the €0,83 million market scenario. Due to the unique and inimitable intellectual property the project is based on, competitors would not be able to create competing offers. Therefore, no first-mover advantages exist and delaying the project commercialization would not result in a permanent loss of market share. Hence, we did not reduce the final market values in the delay tree.

The delay tree had an option value of €0,040 million. From integrating this option value back into the original market tree applying Model 2 resulted in a project valuation of €0,025 million, which was higher than the valuation of €0,019 million from Model 1. Both real options methods, therefore, suggested that the project should be undertaken and are higher than the NPV-approach. Moreover, adding a delay option captured an additional value of €0,040 million in the project valuation. The summary of the valuation outcomes is seen in Figure 28.

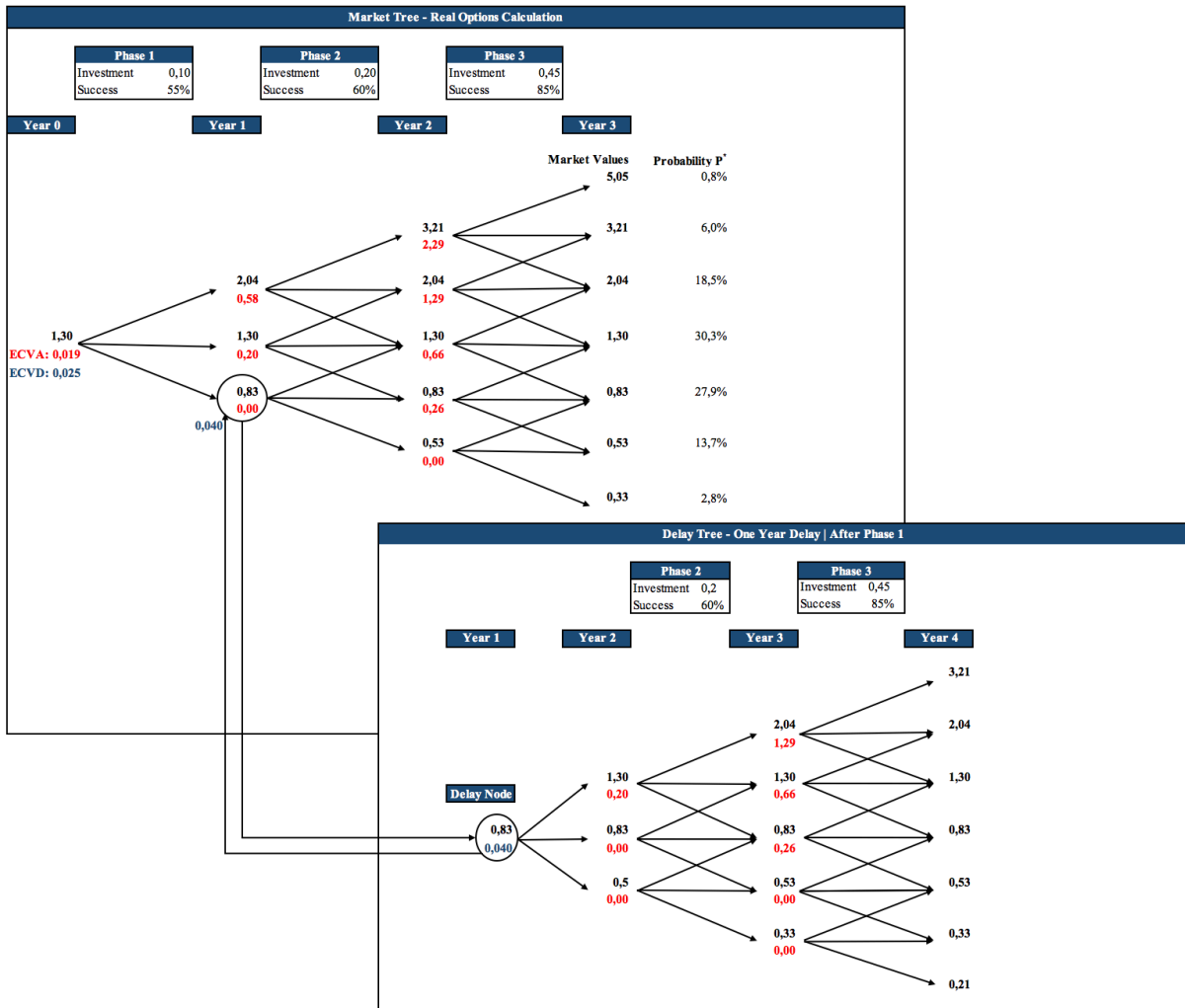

Figure 27: Visualization of the Market and Delay Tree for Case 5 for both Model 1 and Model 2.

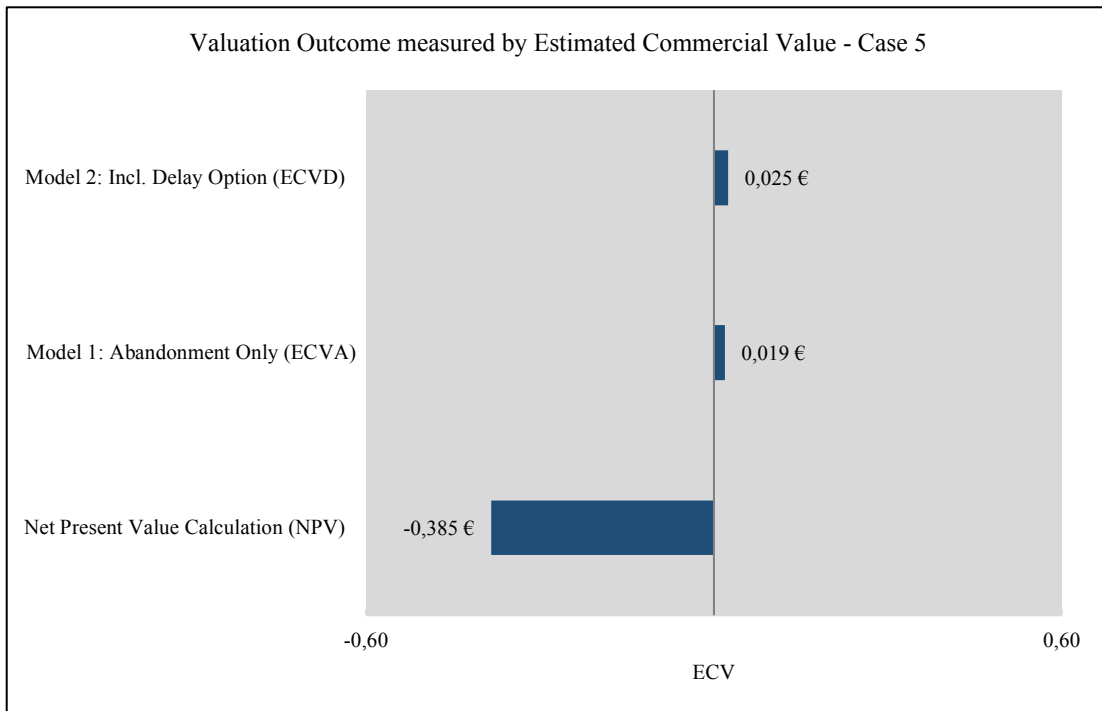

Figure 28: Valuation Outcomes Case 5. Values in Million Euros.

#### 4.1 Case Evaluation – Summary

Five cases of innovation projects have now been discussed in this research with each project exhibiting different levels of market and technical uncertainty as well as a different estimated loss to delay parameters. The figure below summarizes the different levels of these parameters and the valuation outcomes in all three applied valuation methodologies for each case. Moreover, we show how much the percent difference between the valuation in Model 1 and Model 2 was. Once for the initial Loss to delay parameter, and once if we ignore its valuation impact by setting the Loss to Delay equal to zero.

Case	Chance of Technical Failure	Market Volatility Sigma	Case Valuation with Standard Parameters	Added Value of Model 2 in %	Assumed Loss to Delay $l$ per case	Valuation with Loss to Delay $l = 0\%$	Added Value of Model 2 for $l = 0\%$
1	78%	0,37	Model 1: €2,805 million Model 2: €2,805 million NPV: (-) €85,9 million	0,0%	30,0%	€3,135 million	11,8%
2	54%	0,55	Model 1: €0,175 million Model 2: €0,193 million NPV: (-) €1,864 million	10,3%	10%	€0,206 million	17,7%
3	64%	0,49	Model 1: €0,344 million Model 2: €0,344 million NPV: (-) €0,343 million	0,0%	15%	€0,344 million	0,0%
4	29%	0,23	Model 1: €1,346 million Model 2: €1,346 million NPV: (-) €15,95 million	0,0%	40%	€1,480 million	10,0%
5	72%	0,32	Model 1: €0,019 million Model 2: €0,025 million NPV: (-) €0,385 million	32%	0%	€0,025 million	32%
<b>Low/High</b>	29-78%	23-55%		0-32%	0-40%		0-32%
<b>Average</b>	59%	39%		8%	19%		14%

Figure 29: Overview of Case Valuation Results.

The average level of technical uncertainty, as defined by the chance of technical failure, across all cases was 59%. The average level of market uncertainty across cases, as defined by the parameter Sigma, was 39%. Moreover, the spread of technical uncertainty values was higher reaching from 29% to 78%, compared to 23 to 55% for market uncertainty. Our discussed cases seemed to exhibit a higher level of technical than market uncertainty. The estimated Loss to Delay ranged from 0% to 40%, while its average was 19%.

All of the cases in this research showed a negative estimated commercial value with an NPV-approach. Hence, the innovation projects would not have been conducted when following this valuation methodology. Real options Model 1, which included the option to abandon the project, showed a positive estimated commercial value for all cases. Real options Model 2, which included an option to delay, showed a higher valuation than both an NPV-approach and Model 1 for Cases 2 and 5. The highest valuation difference arose for Case 5, with a 32% higher valuation of Model 2 compared to Model 1 which resulted from including a delay option.

For Cases 1, 3 and 4 including an option to delay an investment did not result in any valuation difference between the two real options models. For these cases, the difference in the real options and NPV-valuation solely arose from the inclusion of an abandonment option.

As Model 2 only yielded a higher valuation than Model 1 for Cases 2 and 5, we only find partial evidence for Hypothesis 5. Adding a delay option does not necessarily increase the valuation of a project with a real options approach. Moreover, the added value of the delay option was only 8% on average across all cases and therefore relatively small. However, this is also contingent on the value of the estimated loss to delay parameter which seemed to have a significant negative impact on the delay options value and thereby the valuation difference between Model 1 and Model 2.

To correct for the dependency of the delay options value on the estimated value of the *loss to delay* parameter we also valued all cases with an *l* of zero percent. The resulting valuations can be seen in Figure 29. If the loss to delay parameter was set to zero, Model 2 showed a higher valuation than Model 1 for all cases but Case 4. Again, the highest difference was shown for Case 5, as the loss to delay was assumed to be zero for this case already in the original valuation. Besides this, Case 2 showed a 17,7% higher valuation from Model 2 if *l* was set to zero compared to 10,3% before. Cases 1 and 2, which did initially not show any higher valuation in Model 2, then showed a valuation difference of 11,8% and 10,0% respectively. Interestingly, Case 3 was the only case for which a delay was calculated after project Phase 2 was completed and for which the added value of the delay option remained at 0%.

In general, setting the 'Loss to Delay' to zero did as expected, lead to a higher valuation impact from including a delay option. The added value of the delay option was 14% on average across cases with *l* being set to zero, which was higher than the average difference of 8% with the initial loss to delay values. However, while testing this scenario did provide additional evidence for Hypothesis 5, we can still not find conclusive evidence that a real options approach with a delay option will yield a higher valuation than a real options approach with only an abandonment option. Instead, the impact was dependent on the project's specific characteristics.

For understanding how specific project characteristics as defined by a projects set of input parameters determine a delay options value we performed a sensitivity analysis.

### 4.2 Case Evaluation – Sensitivity Analysis

One of our research questions was which impact market uncertainty, or market uncertainty, has on a delay options value. To understand this relationship, we performed a sensitivity analysis on how the option values for each delay tree within the cases change if market uncertainty varies across a range of 0,2 to 1. Moreover, we simulated these changes for different levels of Loss to Delay  $l$ , as we found during the case valuation that this parameter has a strong influence on the value of a delay option. The analysis was performed for an assumed Loss to Delay of 0, 5, 10 and 15%. All other case parameters were held constant. The real options model used was Model 2.

The results of the sensitivity analysis can be seen in Figure 30 to Figure 34. Each figure shows how the option value of the delay tree varies for different levels of market uncertainty when a particular loss to delay is assumed. Moreover, the figures show how the estimated commercial values, or option value, of the entire project changes over different levels of market uncertainty. The change in project valuation was only measured for a Loss to Delay of 0%, as the parameter only influences the project valuation through the delay option and hence is not able to change how Sigma affects other options values in the market tree.

For all cases, the estimated commercial values, or option values, of the entire project were increasing with market uncertainty across the entire range of Sigma from 20% to 100%. Therefore, an increase in market uncertainty led to an increase in the project valuation within real options Model 2. Moreover, the option values of the entire project were increasing steeper in market uncertainty than the delay option values and thus react more sensitive to it.

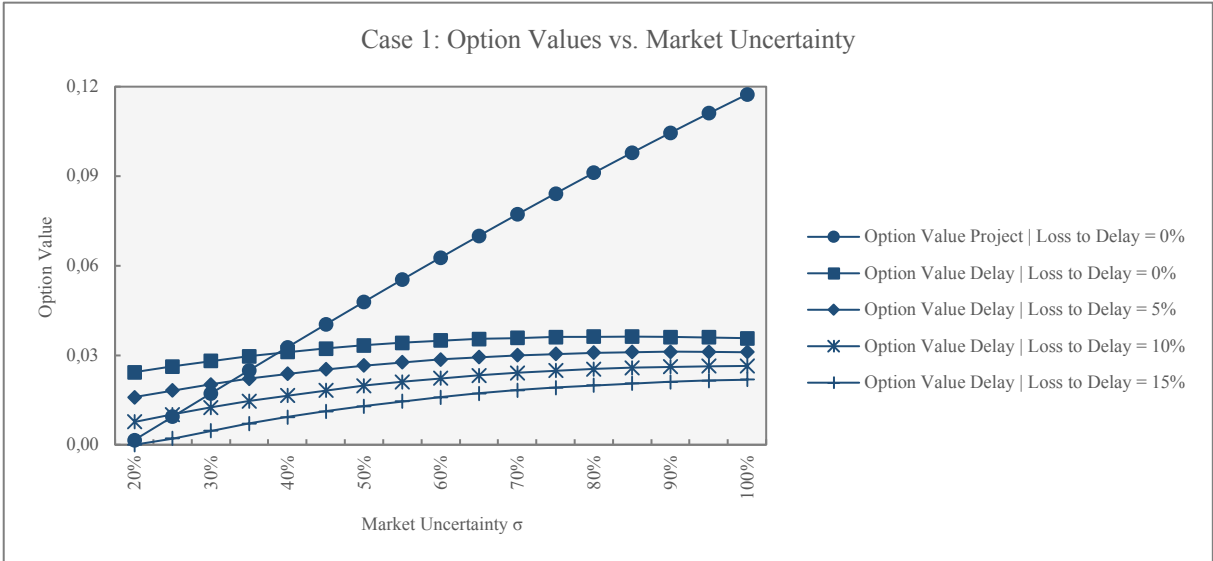

Figure 30: Sensitivity Analysis for Case 1

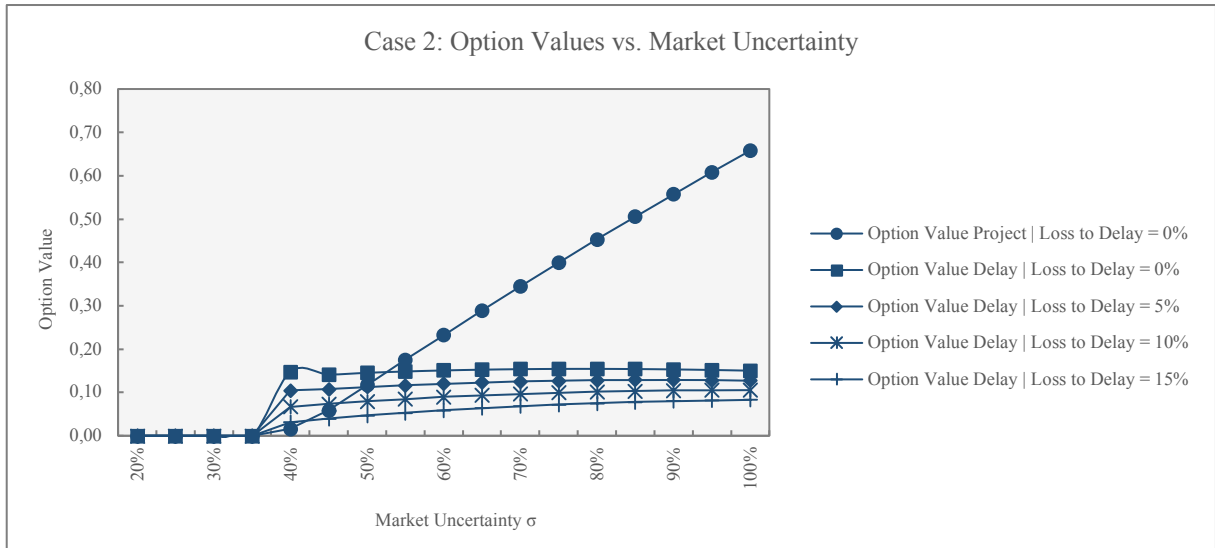

Figure 31: Sensitivity Analysis for Case 2

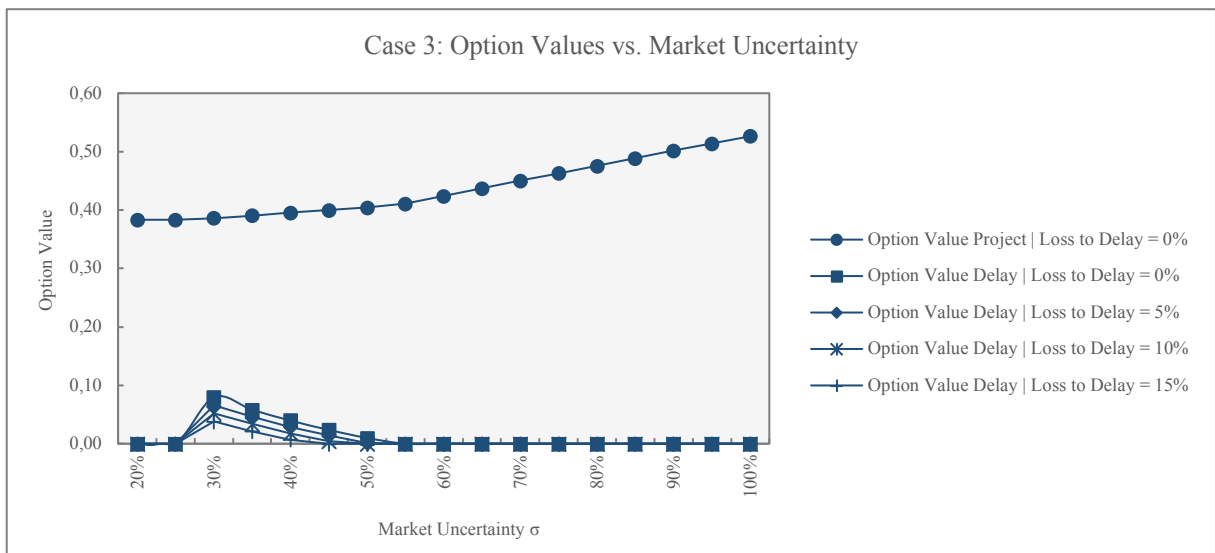

Figure 32: Sensitivity Analysis for Case 3

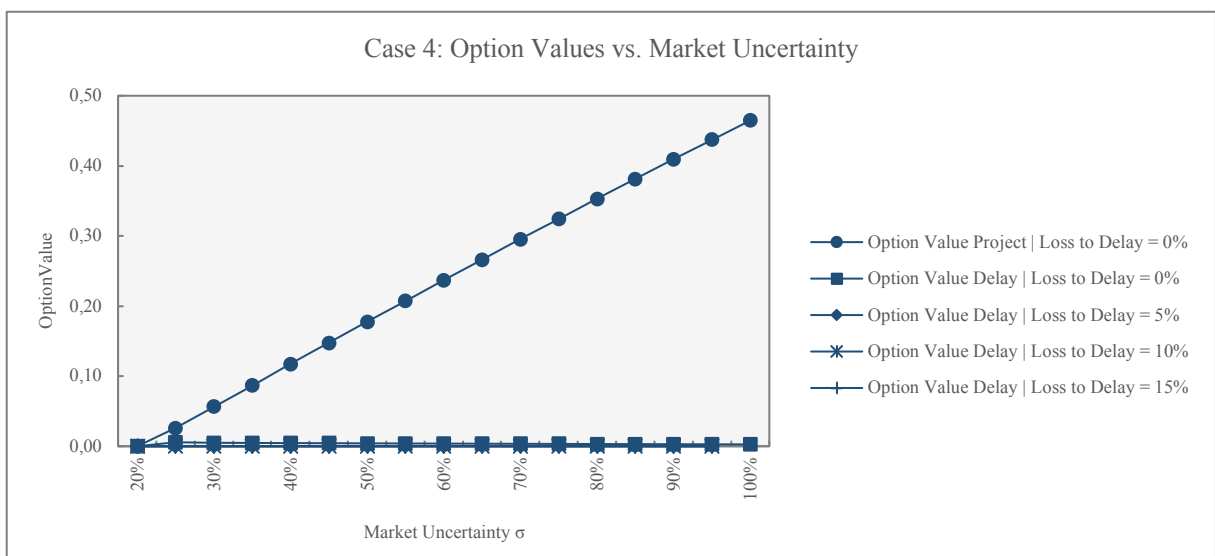

Figure 33: Sensitivity Analysis for Case 4

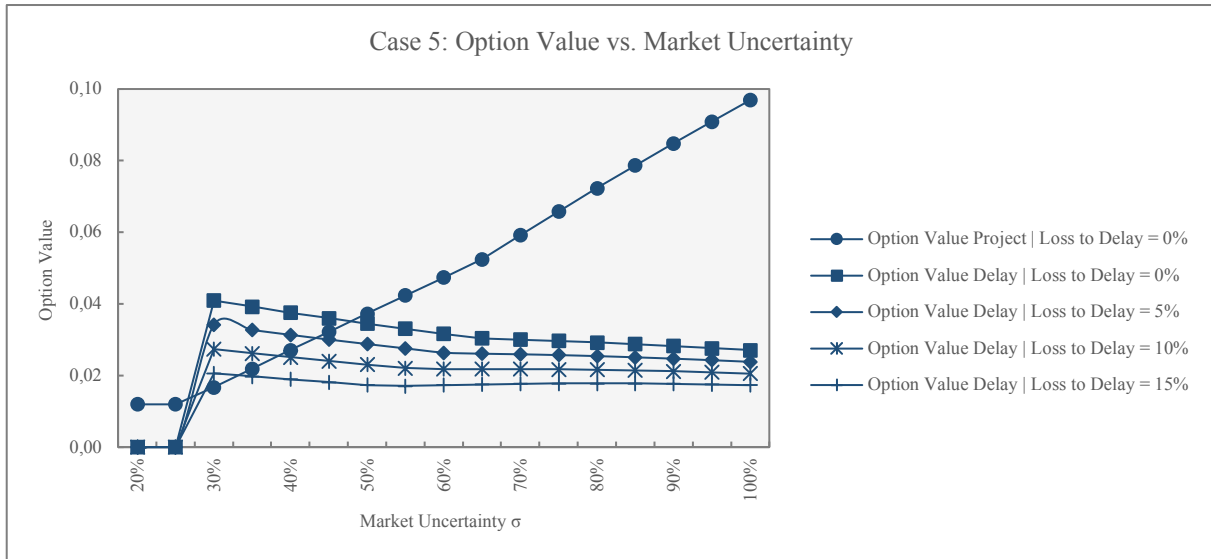

Figure 34: Sensitivity Analysis for Case 5

The delay tree values exhibited a different pattern than the entire project's option value. In all cases but Case 4 the delay tree option values peaked at a certain level of Sigma and kept declining afterwards. Market uncertainty in our cases thereby had an initially positive and then negative effect on the delay option values as measured by the delay trees. Different levels of Loss to Delay  $l$  did not change this observed pattern but instead only lower the delay options values. In Case 4, the delay trees option value was zero for all levels of Sigma if the Loss to Delay was set higher than zero percent. This was due to the already very low value option of the delay tree when  $l$  was equal to zero. If the Loss to Delay was set to zero percent, the delay trees option value followed the same pattern as in the other cases. From our case analysis we can therefore not conclude that the value of the delay option increases in market uncertainty. Instead, the delay option only increases in market uncertainty up to a certain, apparently optimal, point. Hence, we cannot confirm Hypothesis 1.

To gain a better understanding why this pattern occurs, and which parameters influence it, we also performed a sensitivity analysis on the other input parameters of Model 2. This analysis was performed independently of the cases, to gain a more general understanding how a delay options value changes within a real options valuation as the input parameters vary. The results of this analysis will be described in the next section.

### 4.3 Sensitivity Analysis

We performed a sensitivity analysis on Model 2 under different scenarios of delaying an investment. The sensitivity analysis was used to identify which variables (delay discount, market uncertainty, technical uncertainty) have the biggest influence on the outcome of a project valuation including a delay option. This analysis was relevant to understand under which circumstances a delay is most valuable. We measured a delay options value as in the case analysis, by taking the option value of a delay tree that is constructed out of a node with option value 0 in the market tree.

Moreover, we were specifically interested in determining the sensitivity of the option value to market uncertainty in order to answer the proposed research questions. We used Spider Plots to display the sensitivity of the delay options value to the relevant input variables. All graphs can be found in Appendices F to K.

To determine the input sensitivity of the delay option value, we set up a fictitious project, independent of the prior described cases. In Table 4 we list which variables were used as inputs, including their lower and upper boundaries, as well as the fixed inputs we used for building the model. We did not need to determine a high or low market scenario and the respective probabilities, as we did not calculate the projects net present value. As the project was fictitious, all monetary values were assumed to be given in millions.

We did not include the risk-free interest rate  $r$  as an input variable but held it constant at 0,5%. Otherwise, as both  $r$  and the market uncertainty  $\text{Sigma}$  influence the up and down factors of our trinomial model simultaneously, it would have been difficult to isolate their individual effects on the delay options value. Variables that are expressed in percent were fixed with a lower boundary of 0 and an upper boundary of 1. The investments in each phase were constrained with an upper boundary of 100.

Table 4: Inputs for Sensitivity Analysis.

Fixed Input	Value	Input Variable	Boundary [lower; upper]
Average Market Value	100	Delay Loss/Year	[0;1]
Risk-free Rate $r$	0,005	Sigma ( $\sigma$ )	[0;1]
		Technical Success per Phase	[0;1]
		Investment per Phase	[0;100]



Within Model 2, the starting point of a delay tree is a node in the market tree, where the option value is equal to zero. Therefore, we can model delay options for several nodes within the market tree over different points in time.

To determine if our sensitivity analysis results differ, depending on which market value scenario, and thereby when a delay option is done, we performed it for four different scenarios.

Each scenario represents a delay tree being built from a specific market scenario, or node, in the market tree. Thereby, we calculated the option value of delaying an investment for two unfavourable scenarios in Phases 2 and 3 of a project. This is illustrated in Figure 35.

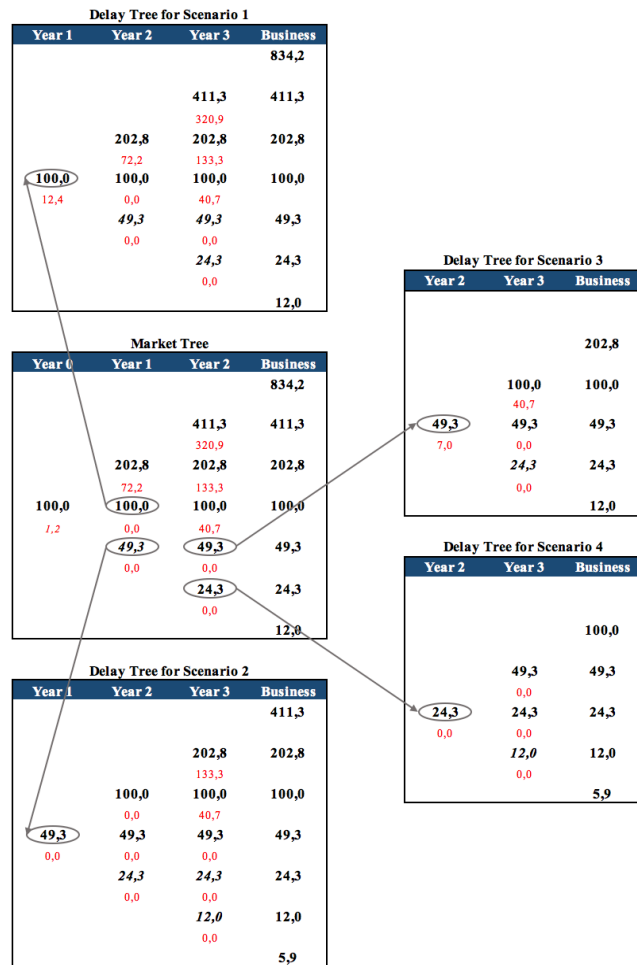

Figure 35: Market Tree Nodes from which Sensitivity Analysis Scenarios were derived (values are placeholders).

One approach to determining the sensitivity of a models output to its inputs is via Monte-Carlo simulations if the input parameters distributions are known. These simulations can be performed with several software packages such as Crystal Ball® and @Risk®. For the simulations, all variables were assumed to be triangular distributions with the lower and upper limits seen in Table 4, and the base case values used as the modes.

The results can be seen in Figure 36 and Figure 37 as well as Appendix E to Appendix J. Per simulation, 15000 iterations were performed. This comparably large number of iterations should provide a reasonable estimate of the impact of the input variables on the delay options value in the four different scenarios. The Figures on the next page show the so-called Spider-Plots for the Option Value of Delaying an Investment in Scenario 2. In Figure 36 the vertical Axis shows the Delay Option Value and the horizontal axis plots the percentile of Sigma within the boundaries we specified in Table 4. The distribution percentile of 50%, reflects a Sigma value of 0,5.

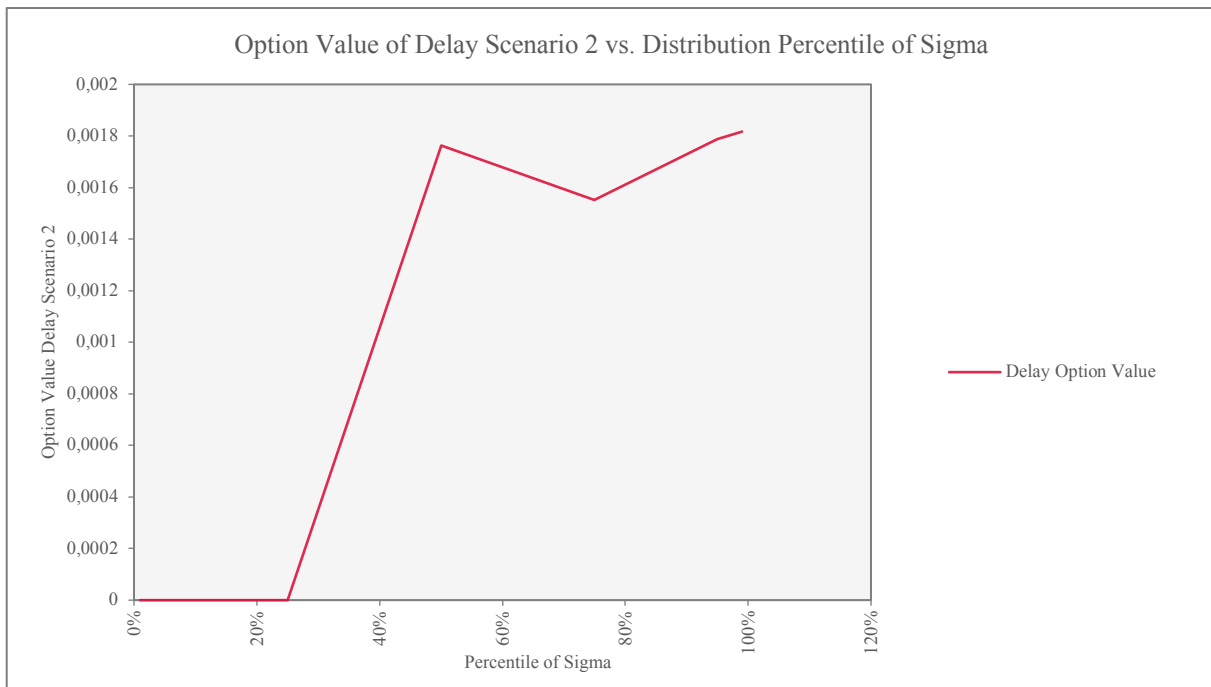

Figure 36: Sigma vs. Delay Option Value in Scenario 2.

In Scenarios 1, 2 and 3, the delay option values kept increasing as Sigma increases to a value of 1 or the 100% distribution percentile, confirming our Hypothesis 1. In Scenario 4, the delay options value decreased after the 25% percentile or a Sigma of 0,25 is exceeded which disconfirmed Hypothesis 1. Referring to Figure 35, this implied that in Scenario 1, in which the market has not moved from its initial value after the first phase, a delay options value increased with Sigma. The same was the case for Scenario 2 and 3 which represented a slightly unfavourable market development. For Scenario 4, which was the least favourable scenario in our market tree, the delay options value only increased in value up to a level of Sigma of 0,25. Hence, we could again not find conclusive evidence that an increase in Market uncertainty will always lead to an increase in the delay options value. Instead, this relationship seems to depend on when within a project an investment delay is exercised. Hypothesis 1 could not be conclusively confirmed.

The Spider Plot in Figure 37 shows the sensitivity of the option value in Scenario 2 to a change in a given input parameter if all other parameters are held constant. A steeper line implies a stronger impact of a given input parameter on the delay options value. Again, further plots can be found in Appendix E to Appendix J. We find that our Loss to Delay parameter has the most substantial impact on the delay options value for all scenarios. The impact of the parameter on the delay options value was higher than the impact of Market Uncertainty, and thereby we can disconfirm Hypothesis 3.

Moreover, a change in the size of the investment sizes per phase or the chances of technical success per phase has a stronger impact on the delay options value than Market Uncertainty in all but Scenario 1. This scenario represented a normal development of the market while only Scenario 2, 3 and 4 represented unfavourable market developments. We can thereby not entirely disconfirm Hypothesis 2, for that only in cases of unfavourable market developments the impact of market uncertainty on the delay options value was lower than the impact of technical uncertainty.

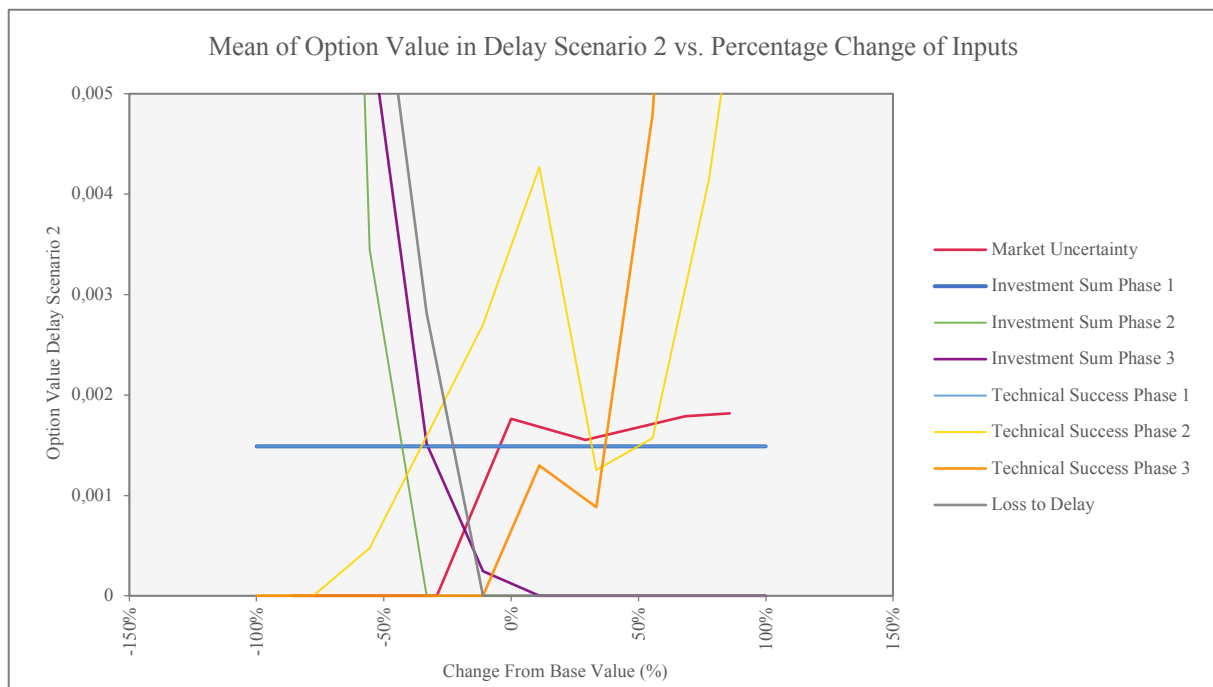

Figure 37: Spider Plot for Input Parameters in Scenario 2.

#### 4.4 Optimization

The last part of our research used Monte-Carlo Simulations to determine if in specific projects including a delay option, and thereby using Model 2, could lead to projects being pursued which would be rejected in Model 1 considering only an abandonment option. This could give an intuition for project circumstances under which considering a delay option will result in significantly higher valuation results than an abandonment option. We used the @Risk Software package to optimize for possible scenarios in which Model 1 yields to a value of zero and Model 2 a value bigger than zero. Again, we assumed a three-phase project with three distinct investments. As the Loss to Delay was irrelevant for the target of our simulation, we set it to zero across all simulations.

We ran the software's OptQuest algorithm with 1000 Trials. This relatively high number of trials gives the algorithm sufficient room to find a solution in Model 2 that is close to globally optimal. However, as the underlying mathematics make the model non-linear, we were not able to determine a globally optimal solution for the delay options value. Instead, all solutions are only the highest local optimum values the optimization algorithm could find for each scenario. As optimization target for the algorithm, we selected to maximize the option value of a delay tree. As base nodes to build the delay tree, we selected the same starting scenarios in the market tree as for the sensitivity analysis (see Figure 35).

Three simulation results were produced per scenario, which can be seen in Figure 38 to Figure 40. Each figure shows one set of parameters for each scenario, for which the estimated commercial value of a project is zero with Model 1, while the value of Model 2 is bigger than zero due to incorporating a delay option. Moreover, the value of Model 2, and therefore the added value from the delay option, is at a local maximum for the given Scenario. In Figure 38, assuming a delay at the Scenario 2 node from Figure 35, the shown set of parameters will lead to an estimated commercial value of 0 for Model 1 and 0,65 for Model 2. The figures also show the percentage of the total investment sum that still needs to be committed to the project immediately before the delay. In Scenario 1 of Figure 38, where a delay is done before Phase 2, 92% of the total sum of all investments still needs to be committed to the project.

Simulation Set 1										
<b>Scenario 1</b>										
Chance of Technical Success				Sigma	Investment Size			Outstanding before Delay	Model 1	Model 2
Phase 1	Phase 2	Phase 3	Total		Phase 1	Phase 2	Phase 3		ECV	ECV
68%	71%	75%	36%	0,70	7,38 €	41,55 €	41,57 €	92%	0,00	3,40
<b>Scenario 2</b>										
Chance of Technical Success				Sigma	Investment Size			Outstanding before Delay	Model 1	Model 2
Phase 1	Phase 2	Phase 3	Total		Phase 1	Phase 2	Phase 3		ECV	ECV
71%	89%	100%	63%	0,73	23,43 €	41,65 €	35,77 €	77%	0,00	0,65
<b>Scenario 3</b>										
Chance of Technical Success				Sigma	Investment Size			Outstanding before Delay	Model 1	Model 2
Phase 1	Phase 2	Phase 3	Total		Phase 1	Phase 2	Phase 3		ECV	ECV
72%	72%	78%	40%	0,67	22,01 €	4,26 €	36,25 €	58%	0,00	0,58
<b>Scenario 4</b>										
Chance of Technical Success				Sigma	Investment Size			Outstanding before Delay	Model 1	Model 2
Phase 1	Phase 2	Phase 3	Total		Phase 1	Phase 2	Phase 3		ECV	ECV
58%	73%	92%	39%	0,66	23,92 €	16,28 €	14,61 €	27%	0,00	0,14

Figure 38: Simulation Set 1 for delays in different scenarios.

In all twelve simulations, Sigma was higher than or equal to 0,66 which is higher than the highest Sigma of 0,55 in the case studies. It, therefore, seems that a scenario where a delay option is especially relevant arises for projects with particularly high degrees of market uncertainty. Moreover, we found that for all simulations except Scenario 4 in Simulation Set 1 and Set 2, the dispersion of investment sizes features an interesting pattern. Firstly, the size of the investment phase before the delayed investment was several multiples smaller than the delayed investment itself. In Figure 39, we can see in the parameter set for Scenario 3 that the delayed investment Phase 3 has a value of 19,97 while the preceding Phase 2 has a value of only 0,42. Second, the percentage of investments still outstanding before the delay relative to the total sum of investments is higher than 50%.

Simulation Set 2										
<b>Scenario 1</b>										
Chance of Technical Success				Sigma	Investment Sizes			Outstanding before Delay	Model 1	Model 2
Phase 1	Phase 2	Phase 3	Total		Phase 1	Phase 2	Phase 3		ECV	ECV
90%	81%	56%	41%	0,78	10,69 €	32,31 €	20,27 €	83%	0,00	4,90
<b>Scenario 2</b>										
Chance of Technical Success				Sigma	Investment Sizes			Outstanding before Delay	Model 1	Model 2
Phase 1	Phase 2	Phase 3	Total		Phase 1	Phase 2	Phase 3		ECV	ECV
84%	67%	55%	31%	0,78	11,46 €	17,10 €	22,79 €	78%	0,00	0,28
<b>Scenario 3</b>										
Chance of Technical Success				Sigma	Investment Sizes			Outstanding before Delay	Model 1	Model 2
Phase 1	Phase 2	Phase 3	Total		Phase 1	Phase 2	Phase 3		ECV	ECV
78%	57%	60%	27%	0,80	18,92 €	0,42 €	19,97 €	51%	0,00	0,44
<b>Scenario 4</b>										
Chance of Technical Success				Sigma	Investment Sizes			Outstanding before Delay	Model 1	Model 2
Phase 1	Phase 2	Phase 3	Total		Phase 1	Phase 2	Phase 3		ECV	ECV
73%	55%	69%	27%	0,80	19,69 €	1,17 €	19,97 €	49%	0,00	0,02

Figure 39: Simulation Set 2 for delays in different scenarios.

This means that the simulation results were produced for a set of parameters where the majority of the investments would happen after the delay, with the only outlier being the aforementioned Scenario 4 in Simulation Set 1 and Set 2. It seems a delay option can have a significantly higher valuation impact than an abandonment option if the majority of investments are committed to the project only after an eventual delay. This provides some evidence to Hypothesis 4, even though only ten out of twelve simulations exhibited such a pattern. Lastly, no consistent pattern was found for the chance of technical success in each phase in regard to the simulation results.

Simulation Set 3										
<b>Scenario 1</b>										
Chance of Technical Success				Sigma	Investment Sizes			Outstanding before Delay	Model 1	Model 2
Phase 1	Phase 2	Phase 3	Total		Phase 1	Phase 2	Phase 3		ECV	ECV
93%	87%	85%	68%	0,98	17,48 €	118,31 €	12,97 €	88%	0,00	7,70
<b>Scenario 2</b>										
Chance of Technical Success				Sigma	Investment Sizes			Outstanding before Delay	Model 1	Model 2
Phase 1	Phase 2	Phase 3	Total		Phase 1	Phase 2	Phase 3		ECV	ECV
73%	81%	70%	42%	0,75	14,52 €	26,55 €	29,64 €	79%	0,00	0,34
<b>Scenario 3</b>										
Chance of Technical Success				Sigma	Investment Sizes			Outstanding before Delay	Model 1	Model 2
Phase 1	Phase 2	Phase 3	Total		Phase 1	Phase 2	Phase 3		ECV	ECV
43%	81%	70%	25%	0,74	14,46 €	4,40 €	28,94 €	61%	0,00	0,37
<b>Scenario 4</b>										
Chance of Technical Success				Sigma	Investment Sizes			Outstanding before Delay	Model 1	Model 2
Phase 1	Phase 2	Phase 3	Total		Phase 1	Phase 2	Phase 3		ECV	ECV
83%	39%	98%	32%	0,73	22,76 €	1,34 €	27,42 €	53%	0,00	0,05

Figure 40: Simulation Set 3 for delays in different scenarios

## 5. DISCUSSION

The purpose of this study was to understand how delay options, as characterized by investment delays, impact the real options valuation of innovation projects. In light of this, our primary research question was – ‘*what is the impact of investment delays within a real options model on the valuation of an innovation project?*’. In addition to this, prior research has stressed the importance of market uncertainty in positively affecting a delay options value. We examined if this is indeed the case by asking our second research question – ‘*What is the impact of market uncertainty on the value of a delay option and is it the most important value driver?*’. Lastly, past research mentioned the importance of accounting for potential costs from preemption following the delay when assessing the options value. Our last question was therefore – ‘*How do costs associated with an investment delay impact the value of a delay option and the overall project valuation?*’. This exploratory study tried to answer these questions by developing a novel valuation model that includes a delay option and analyzing its valuation outcome in five case studies. Moreover, we analyzed the delay options value in the model via sensitivity analysis and optimization methods.

After having conducted our analysis with the help of several hypotheses, we found evidence to provide an initial answer to these questions. Table 5 summarizes the results of our study and which hypotheses were rejected or supported by our research methods. Overall our results were not entirely conclusively as for all hypothesis there was at least one outlier in our datasets which did not conform to them. However, considering the exploratory nature of this study, we still deem our findings as adequate to provide some additional insights into the research on delay options.

	Hypothesis 1	Hypothesis 2	Hypothesis 3	Hypothesis 4	Hypothesis 5
	<i>The value of a delay option in innovation projects will increase in market uncertainty.</i>	<i>The impact of market uncertainty on a delay options value is higher than the impact of technical uncertainty.</i>	<i>The impact of market uncertainty on a delay options value is higher than the impact costs of delaying have on the options value.</i>	<i>A delay option will show a higher value for projects in which the majority of the investment sum is committed subsequent to the delay.</i>	<i>A Real options model with a delay option (Model 2), will yield a higher valuation than a real options model with an abandonment option (Model 1).</i>
Case analysis	-	-	-	-	Partially Supported
Sensitivity Analysis	Partially Supported	Partially Supported	Rejected	-	-
Optimization	-	-	-	Partially Supported	-

*Table 5: Summary of Acceptance or Rejection of Hypothesis. (-) means hypothesis was not tested via a certain method.*

We did find some evidence that adding a delay option into a real options model can indeed lead to a higher valuation compared to a model with only an abandonment option. Specifically, for projects with high market uncertainty and where the majority of investments is only committed after the delay, a real options model with a delay option can yield a significantly higher valuation than an abandonment options approach. However, the value a delay option provides was is seemingly also heavily dependent on the other input parameters of a project.

The loss to delay parameter created in this research had the highest impact on a delay options value among all input parameters. While market uncertainty did as predicted lead to a higher valuation of a delay option and thereby had a positive impact on it, this relationship was more complex than expected. Further, its overall impact on the valuation is lower than technical uncertainty and the loss to delay.

In sum, our findings do provide some insight into how delay options behave when examined on a project level of analysis and provide an approach to valuing delay options which future research can refine. It is important for managers to understand that applying a real options model including delay options can yield to a higher valuation than both regular real options as well as Net-Present-Value approaches. This also holds if a real options approach with abandonment options does yield a valuation of zero. Specifically, in projects with high levels of market uncertainty but low risk of competitive preemption, such a pattern seems to occur. In the subsequent sections, we will elaborate and discuss our results.

## **5.1 Market uncertainty and delay options**

Hypothesis 1 predicted that a delay options value would increase in market uncertainty. The findings were largely in line with our hypothesis. Our results suggest that a delay options value peaks at high levels of market uncertainty and then seems to decline or at least stagnate with rising uncertainty. This pattern occurred across all cases in our case analysis, and the peak value was different in each case.

Interestingly, within our sensitivity analysis we found the same pattern only for the scenario in which the market had developed least favorably preceding the delay. For all other scenarios, the results implied that the mean option value keeps increasing with uncertainty.

We explain this seemingly disagreeing patterns by the difference in methodology by which the sensitivity analysis on the cases and the artificial scenarios was performed. In the later, we approximated a mean of how the delay option value in a scenario changes with market uncertainty across 15000 different sets of input parameters with 4 data points measured. In the case analysis, we varied market uncertainty for only the single input parameter set given by the



interviewed practitioners however across 20 data points. The results of the scenario-based sensitivity analysis can be seen as a more robust and generalizable relationship between market uncertainty and the delay options value. We can thereby assume that market uncertainty generally increases the delay options value in most scenarios. However, as seen in the case analysis there are also projects for which this relationship does not hold at all level of market uncertainty, depending on the other input parameters.

This conclusion is similar to what Oriani and Sobrero (2008) and Folta and O'Brien (2004) argue, in that uncertainty does not have a linear effect on the valuation of R&D capital. Both studies do however argue that this is due to the interplay of the different effects of options present in the investment project. In comparison to Oriani and Sobrero (2008), we cannot replicate the u-shaped relationship between market uncertainty and the valuation of R&D capital in our project valuations. This applies to both the innovation projects total option values and the delay options within the projects itself. We assume this difference results from the different level of analysis, as we focused on innovation projects while Oriani and Sobrero (2008) studied the market valuation of R&D capital. The implication here from is that real options might react differently to uncertainty depending on the level of analysis they are modelled on. We suggest that further research should aim to explore the relationship between delay options and uncertainty in more depth on a project level of analysis.

## **5.2 The Drivers of a Delay Options Value**

Besides a positive impact on the delay options value, we also predicted in Hypothesis 2 that market uncertainty would be a stronger driver for its value than technical uncertainty. The results of our sensitivity analysis did however mostly not confirm this pattern. Across three out of four modelled market scenarios, we found that technical uncertainty exhibited a stronger impact on the delay options value than market uncertainty. The difference in the scenario for which the market uncertainty exhibited a stronger relationship than technical uncertainty was that it modelled the most favorable market development preceding the delay. Interestingly, market uncertainty only had a higher impact as it started exceeding a value of roughly 0,3. This scenario was also the only one for which market uncertainty showed a higher impact than the investment sizes per phase.

These results imply that hypothesis 2 only holds true for scenarios in which a delay is exercised under unfavorable market conditions. In other scenarios market uncertainty seems to play a more important role in determining the delay options value than technical uncertainty. Thereby,

our findings are largely in line with the conclusion by Oriani and Sobrero (2008) that technical uncertainty is more relevant than market uncertainty as it primarily affects companies survival while the later mostly affects future growth opportunities. As the authors argue this in the sense of why a distinction between both sources of uncertainty is relevant, our study provides further evidence why splitting uncertainty into its components is important when valuing projects.

Moreover, in all scenarios the loss to delay seemed to exhibit a stronger impact on the delay options value than market uncertainty, leading us to reject Hypothesis 3. This is roughly in line with the argument of Folta and O'Brien (2004) that the value of the option to delay investment decreases the more competitive advantages to moving early and in turn costs to moving late exist. It also underlines the argument of Lewis et al. (2007), that the cost of delay can kill the options value and should thereby be included in real options models. As this study was exploratory we can however not say with certainty that we modelled the cost of delaying in the most reliable way. Specifically, as our parameter is completely dependent on subjective managerial estimates. Future research could try to find less subjective ways to conceptualize this cost of delaying in real options for projects.

### **5.3 Impact of a Delay Option on Project Valuation**

Hypothesis 4 tried to answer if a delay option would show a higher value for projects in which the majority of the investment sum is committed subsequent to the delay. Our results suggest that this might be indeed the case. Ten out of twelve Monte-Carlo simulation results showed a pattern where the majority of the investment was still outstanding at the time of the delay. Moreover, our simulation results were produced under the requirement that a regular real options approach with an abandonment option would yield a project valuation of zero. Interestingly, all simulation which were generated under the aforementioned conditions also showed a higher market uncertainty than our real-life cases. Our results thereby imply that a delay option can in fact substantially impact project valuations, especially if the majority of the investment sum would only be committed after an eventual delay and there is very high market uncertainty. Moreover, a real options approach with only the option to abandon the project might yield a much less favorable valuation in such circumstances than when using delay options. This is an important implication for radical innovations projects where market uncertainty can be very high, and delay options should, therefore, be considered when valuing the project. However, further research should strive to get a clearer idea for which specific project circumstances a delay option valuation diverges heavily from an abandonment option

valuation. Our exploratory research provides an intuition on how market uncertainty and the structure of investments do play a role in this divergence. Future studies should try to understand if technical uncertainty, especially in multi-staged innovation projects, affects the valuation difference between a delay option valuation and an abandonment option valuation.

Our last hypothesis was that a valuation in our delay options model would yield a higher project valuation than a valuation in an abandonment option model. We did find partial evidence for this hypothesis in that only two out of five cases in our case analysis showed a higher valuation with a delay options model. When not including the loss to delay parameter in the valuation, four out of five cases showed a higher valuation in the delay options model. Moreover, the valuation differences were up to 32%, which is evidence that delay options can indeed play a very important role in the valuation of projects. However, our findings also imply that delay options are not meaningful across all projects but rather more relevant for some types of projects than others. As mentioned before, we did, however, find some evidence that delay options might be specifically important in radical innovation projects which are often subject to high market uncertainty and low initial investments.

#### **5.4 Theoretical Contributions and Implications**

Compared to previous research on real options, our study is the first to analyze delay options within the setting of innovation projects. Further, to our knowledge, no prior study has tried to implement delay options in project valuation models or even analyzed its value on a project level of analysis. In a world where innovation projects are becoming more prevalent in organizations and in which new markets are subject to first-mover advantages, companies need valuation tools that can account for flexibility in spite of these challenges.

What we have shown in this research is that the relation between delay options and project valuations are more complex than initially expected. Future research can build on these findings to see how this relationship differs across different types of projects and to understand how exactly delay options interact with market uncertainty in projects. Further, the interaction of the delay option with other types of options present in projects, such as growth options, deserves more attention.

Moreover, we followed the recommendation by Ragozzino et al. (2016) to research the options available to companies and the optimal timing of exercise. We provided initial research on how

delay options behave and under what contingencies an exercise might be specifically interesting. First, our results imply that delay options are an important component for real options valuations, especially if the project is subject to high market uncertainty and has low initial investments. Second, we have shown that the argument McDonald and Siegel (1986) made more than 30 years ago, in that delay options have to be carefully evaluated against their costs is valid. If costs are ignored including delay options could lead to an overvaluation of projects with a real options approach. Third, we have shown that market uncertainty generally has a positive impact on an option to delay even though the relationship is more complex than expected. Lastly, we have found that technical uncertainty generally plays a more important role in determining the role of a delay option than market uncertainty.

In addition to our theoretical contributions, our findings also have some practical implications for managers. Using delay options in real options models can provide additional flexibility and an alternative valuation approach to traditional real options techniques. Specifically, we found that in innovation projects which are not valued to be worthwhile with an abandonment options approach, a delay options approach might lead to the suggestion to pursue the project instead. The underlying reason is that a delay option gives organizations the opportunity to still capture future cash-flows if the project is proceeded with under better market conditions. Our delay options approach thereby gives managers additional flexibility as the opportunity costs of a delay are not as severe an outright abandonment.

The only requirement for applying this methodology is that the project can be stopped and continued at a later point in time without extreme cost. Moreover, managers need to be able to estimate the cost their delay will have and possible first-mover actions by competitors that their organization would have to cope with. In such cases, our methodology does provide a possibility to value innovation projects and can provide an additional intuition for a project's value. Due to the assumptions and the sensitivity of the model to managerial estimates we do however recommend using a delay options approach in conjunction with a traditional real options approach and NPV-methods.

## **5.5 Limitations**

The findings and conclusions herein provide a basis for further research findings but have to be seen in light of the nature of this study. This research is exploratory in nature and the first to examine delay options in a valuation model used for radical innovation projects.

As mentioned before, it is therefore subject to several limitations that have to be considered when interpreting the results.

Our aim was to understand how delay options do impact innovation project valuations by developing a model that is transparent and usable in practice. Any model requires some simplifications to real-life in order to work. A major simplification that we assumed when creating our delay options model was that the project could be resumed and continued at a later point in time without complications. In real-life projects, it is often not possible to stop all processes at will and resume them later on. Instead, project delays can cause additional internal costs to an organization or yield other complications. These costs or potential problems are likely to differ in nature depending on a projects specific context. Therefore, we could not possibly account for them in our real options valuations. This also means that our delay option valuations are in all likelihood far from realistic. However, any valuation model does make some assumptions by its nature, and no model can ever provide the one true valuation outcome. While our model is therefore not perfect, it can still be used as an auxiliary real options technique to assist managers in innovation project valuation.

As mentioned in our literature review, real options valuations are often different depending on the mathematical model that is used by them. We used a trinomial lattice to build the models in this study. Such a lattice does have drawbacks, for example, in that has a high dispersion of final market scenarios and assumes they are lognormally distributed. This is very different from NPV-techniques and limits the comparability of the valuation outcomes between the different valuation techniques. Future studies might try to use other lattices to make real options valuations more comparable to NPV-approaches. Specifically, using lattices that model double-barrier options in finance could provide an interesting basis for real options models.

Due to the effort required to develop this study's methodology and thereby time-constraints, we were only able to collect data from five radical innovation projects. Given the range of potential innovation projects it is doubtful whether our sample is representative for all projects. Especially since projects in industries with low investment costs, such as software development, might be more suitable for applying a delay options approach, than for example capital-intensive industries where interest rates make delays unfeasible or very expensive. Nevertheless, this study is first of its kind in the field of delay options and merely aims to provide a basis for future research. Trying to analyze the patterns found in this study across a wider-range of industries and projects might be an aim of future research.

## 6. CONCLUSION

---

As new technologies are being introduced at an ever-faster pace, innovation is becoming a priority for many organizations. A characteristic of innovation projects, especially if they are radical, is that they are often risky and subject to many uncertainties regarding market and technology. It is therefore paramount to manage these projects in an appropriate way using an appropriate set of valuation tools. Real options techniques can capture the flexibility needed in innovation projects. However, it is important that managers make deliberate choices about which options to include in their real options models for these models to provide accurate valuations. Ragozzino et al. (2016) stressed the importance of researching and implementing a variety of options into models, such as the option to delay investment. McDonald and Siegel (1986) already argued about the importance of investment delays in 1986, however, no study had attempted to incorporate this option into project valuation models so far.

Using delay options can lead to significantly different valuation outcomes than other real options models and can even suggest proceeding with risky innovation projects that would be abandoned when following other real options approaches. The findings of this research suggest that these valuation differences are especially prevalent when market uncertainty is high, and the majority of investments are made towards a project's end. This is often the case in radical innovation projects. The findings mentioned above are important as they provide an inspiration for future research and evidence that delay options should be considered by practitioners when constructing real options models. Future studies could continue to study the behavior and implementation of different options in projects and try to improve the applicability of real options approaches. Thereby, the real options technique could finally live up to its merits in practice and allow managers to assess innovation projects in the financially most accurate way.

## REFERENCES

---

- Black, F. and Scholes, M., 1973. The Pricing of Options and Corporate Liabilities. *Journal of Political Economy*, 81(3), pp. 637–654.
- Bloom, N., and Van Reenen, J., 2002. Patents, Real Options and Firm Performance. *The Economic Journal*, 112(478), pp. 97–116.
- Boyle, P. P., 1986. Option valuation using a three jump process. *International Options Journal*, 3, pp. 7–12.
- Copeland, T. and Tufano, P., 2004. A real world way to manage real options. *Harvard Business Review*, 82(3), pp. 1–12.
- Cottrell, T. and Sick, G., 2002. Real options and follower strategies: The loss of real option value to first-mover advantage. *Engineering Economist*, 47(3), pp. 232–263.
- Cox, J. C., Ross, S. A. and Rubinstein, M., 1979. Option pricing: A simplified approach. *Journal of Financial Economics*, 7(3), pp. 229–263.
- Creswell, J. W., 2013. Five Qualitative Approaches to Inquiry. *Qualitative Inquiry & Research Design: Choosing Among Five Approaches*, pp. 69–110.
- Dul, J. and Hak, T., 2008. *Case Study Methodology in Business Research*. New York (Vol. 129).
- Eisenhardt, K. M., 1989. Building Theories from Case Study Research. *Academy of Management Review*, 14(4), pp. 532–550.
- Eschenbach, T. G., Lewis, N. A. and Hartman, J. C., 2009. Technical Note: Waiting Cost Models for Real Options. *The Engineering Economist*, 54(1), pp. 1–21.
- Folta, T. B. and O'Brien, J. P., 2004. Entry in the presence of dueling options. *Strategic Management Journal*, 25(2), pp. 121–138.
- Haahtela, T., 2006. Extended Binomial Tree Valuation when the Underlying Asset Distribution is Shifted Lognormal with Higher Moments. *In 10th Annual International Conference on Real Options*, pp. 1–21. Retrieved from [http://www.realoptions.org/papers2006/Haahtela\\_Final.pdf](http://www.realoptions.org/papers2006/Haahtela_Final.pdf)
- Hartmann, M. and Hassan, A., 2006. Application of real options analysis for pharmaceutical R&D project valuation-Empirical results from a survey. *Research Policy*, 35(3), pp. 343–354.
- Hull, J.C., 2014. *Options, Futures, and Other Derivatives* (9<sup>th</sup> edition). Prentice-Hall Int., Upper Saddle River, New Jersey.
- Kamrad, B. and Ritchken, P., 1991. Multinomial Approximating Models for Options with k State Variables. *Management Science*, 37(12), pp. 1640–1652.

- Lee, K.-J., Shyu, D. S. and Dai, M.-L., 2009. The Valuation of Information Technology Investments by Real Options Analysis. *Review of Pacific Basin Financial Markets and Policies*, 12(4), pp. 611–628.
- Lewis, N. A., Eschenbach, T. and Hartman, J. C., 2007. Sensitivity analysis of a real options problem. *IIE Annual Conference and Expo 2007 - Industrial Engineering's Critical Role in a Flat World - Conference Proceedings*, 245–250. Retrieved from <http://www.scopus.com/scopus/inward/record.url?eid=2-s2.0-44949101240&partnerID=40>
- MacMillan, I. C. and McGrath, R. G., 2002. Crafting R&D Project Portfolios. *Research-Technology Management*, 45(5), pp. 48–59.
- McDonald, R. and Siegel, D., 1986. the Value of Waiting To Invest. *Quarterly Journal of Economics*, 101(4), pp. 707–727.
- McGrath, R. G., 1997. A real options logic for initiating technology positioning investments. *Academy of Management Review*, 22(4), pp. 974–996.
- McGrath, R. G. and MacMillan, I. C., 2000. Assessing Technology Projects Using Real Options Reasoning. *Research Technology Management*, 43(4), pp. 35–49.
- McGrath, R.G. and Nerkar, A., 2004. Real options reasoning and a new look at the R&D investment strategies of pharmaceutical firms. *Strategic Management Journal*, 25(1), pp. 1–21.
- Myers, S.C., 1984. Finance Theory and Financial Strategy. *Interfaces* 14(1), pp. 126–137.
- Oriani, R. and Sobrero, M., 2008. Uncertainty and the market valuation of R&D within a real options logic. *Strategic Management Journal*, 29(4), pp. 343–361.
- Paul Clifford and Oleg Zaboronski., 2008. Pricing Options Using Trinomial Trees, pp. 1–12. Retrieved from [https://warwick.ac.uk/fac/sci/math/people/staff/oleg\\_zaboronski/fm/trinomial\\_tree\\_2008.pdf](https://warwick.ac.uk/fac/sci/math/people/staff/oleg_zaboronski/fm/trinomial_tree_2008.pdf)
- Ragozzino, R., Reuer, J. J. and Trigeorgis, L., 2016. Real Options in Strategy and Finance: Current Gaps and Future Linkages. *Academy of Management Perspectives*, 30(4), pp. 428–440.
- Ritchken, P., 1995. On Pricing Barrier Options. *Journal of Derivatives*, 3(2), pp. 19–28.
- Suarez, F. F. and Lanzolla, G., 2007. The role of environmental dynamics in building a first mover advantage theory. *Academy of Management Review*, 32(2), pp. 377–392.



- Trigeorgis, L., 1993. The Nature of Option Interactions and the Valuation of Investments with Multiple Real Options. *The Journal of Financial and Quantitative Analysis*, 28(1), pp. 1–20.
- Urban, G. L., Carter, T., Gaskin, S. and Mucha, Z., 1986. Market Share Rewards to Pioneering Brands: An Empirical Analysis and Strategic Implications. *Management Science*, 32(6), pp. 645–659.
- Van Den Ende, J., 2016. A real simple real options methodology for innovation projects, pp. 1–16.
- Weeds, H., 2002. Strategic Delay in a Real Options Model of R&D Competition. *Review of Economic Studies*, 69(3), pp. 729–747.
- Yin, R. K., 2003. *Case Study Research: Design & Methods* (3<sup>rd</sup> edition). Thousand Oaks, CA: Sage.

# APPENDIX

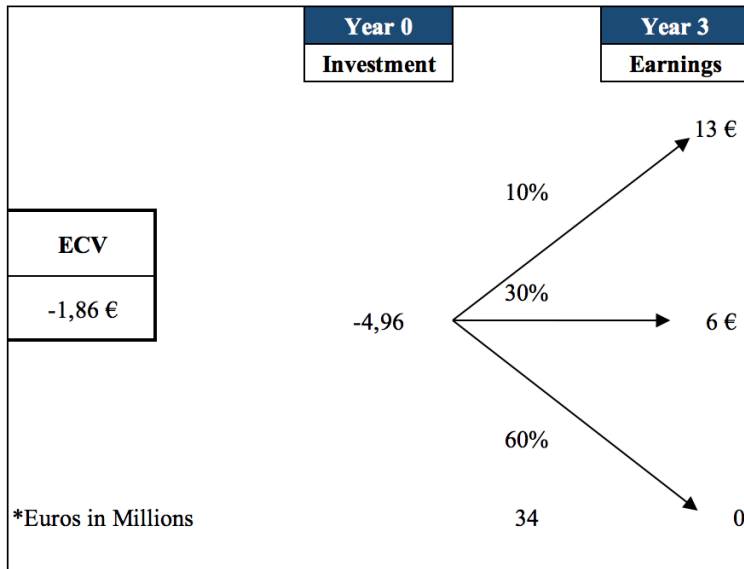

*Appendix A: NPV Calculation Case 2*

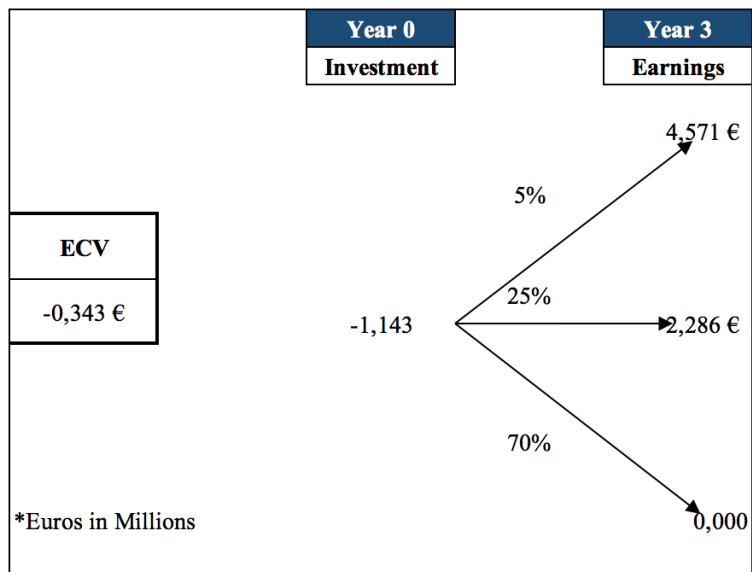

*Appendix B: NPV Calculation Case 3*

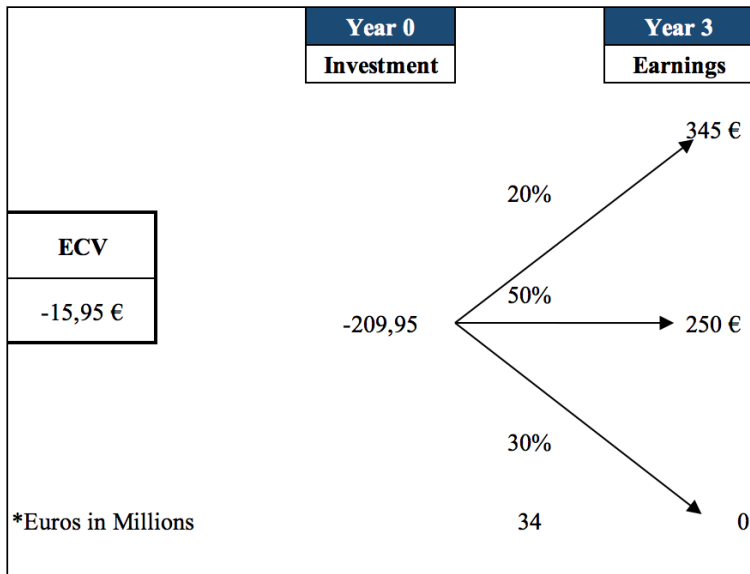

Appendix C: NPV Calculation Case 4

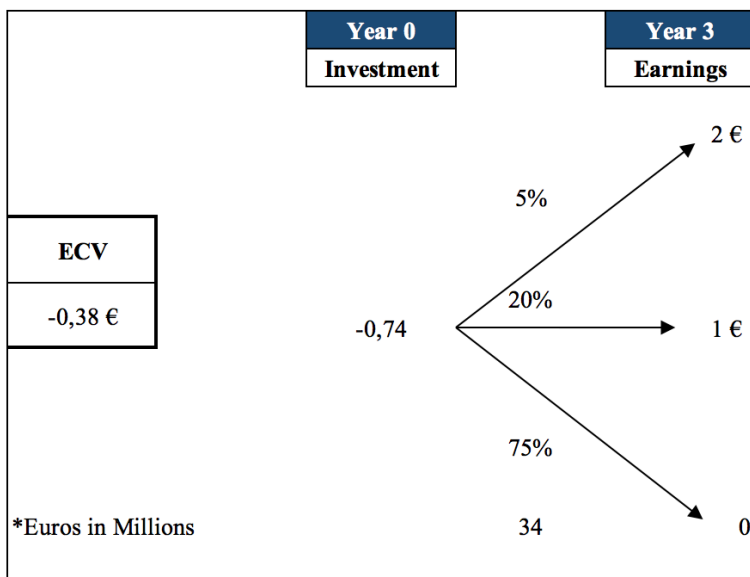

Appendix D: NPV Calculation Case 5

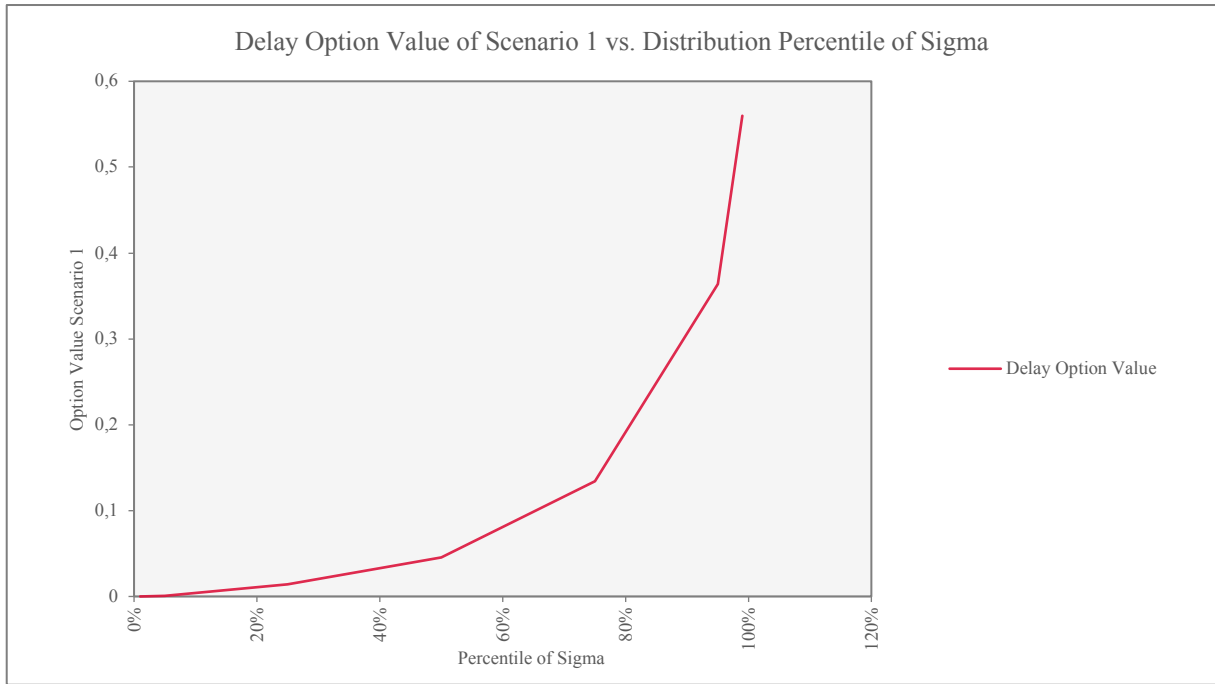

Appendix E: Sigma vs. Delay Option Value Scenario 1.

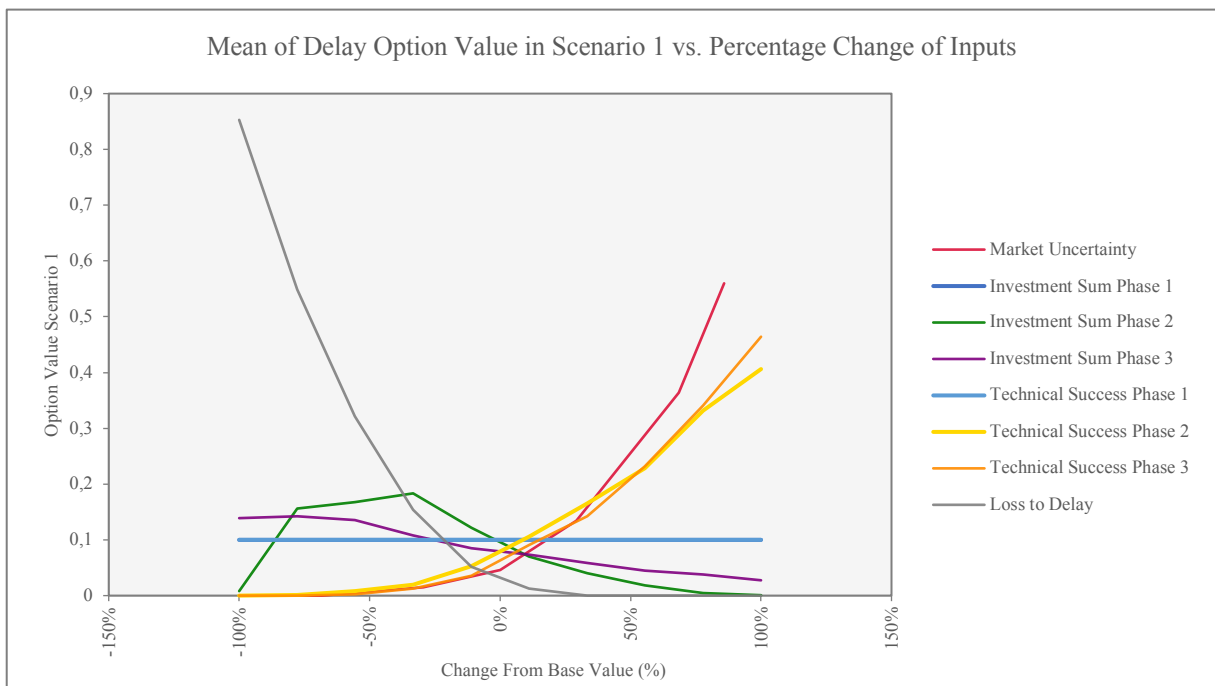

Appendix F: Spider Plot for Input Parameters in Scenario 1.

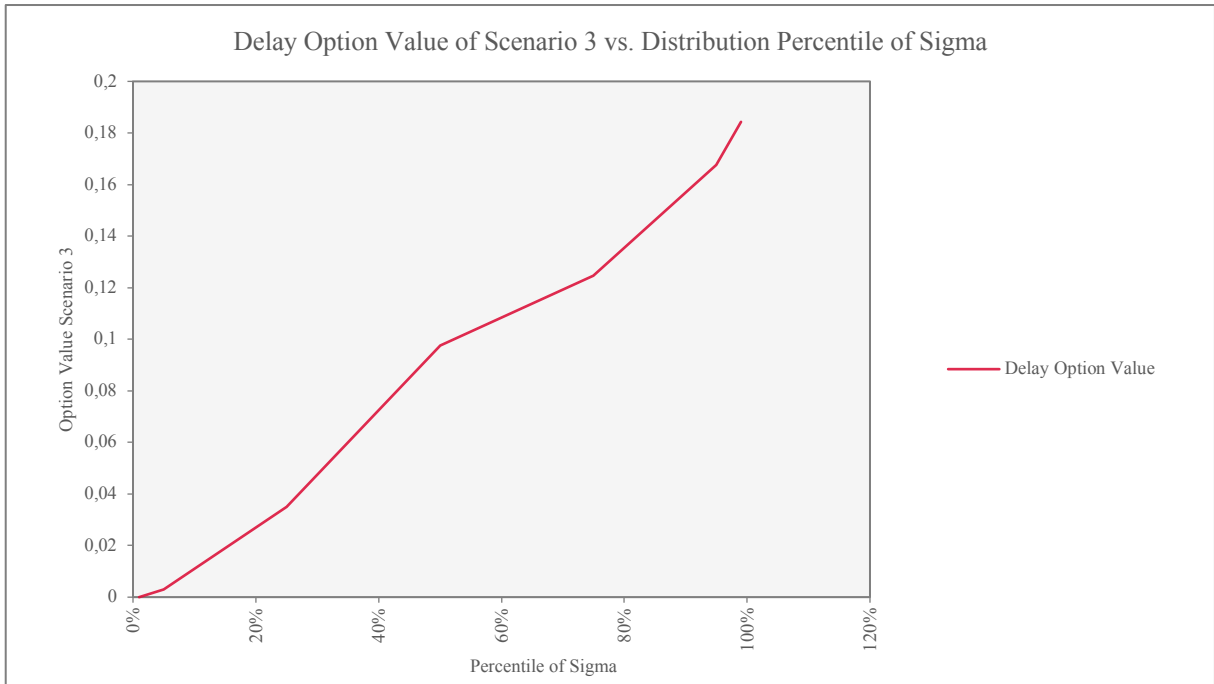

Appendix G: Sigma vs. Delay Option Value Scenario 3.

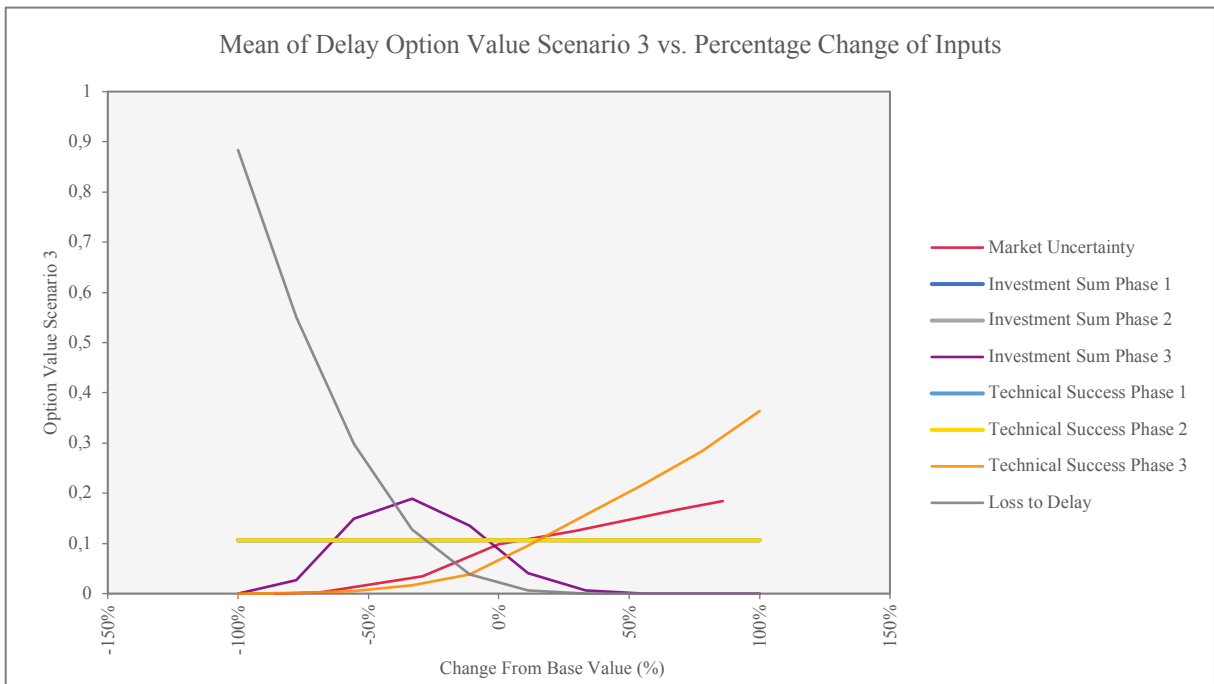

Appendix H: Spider Plot for Input Parameters in Scenario 3.

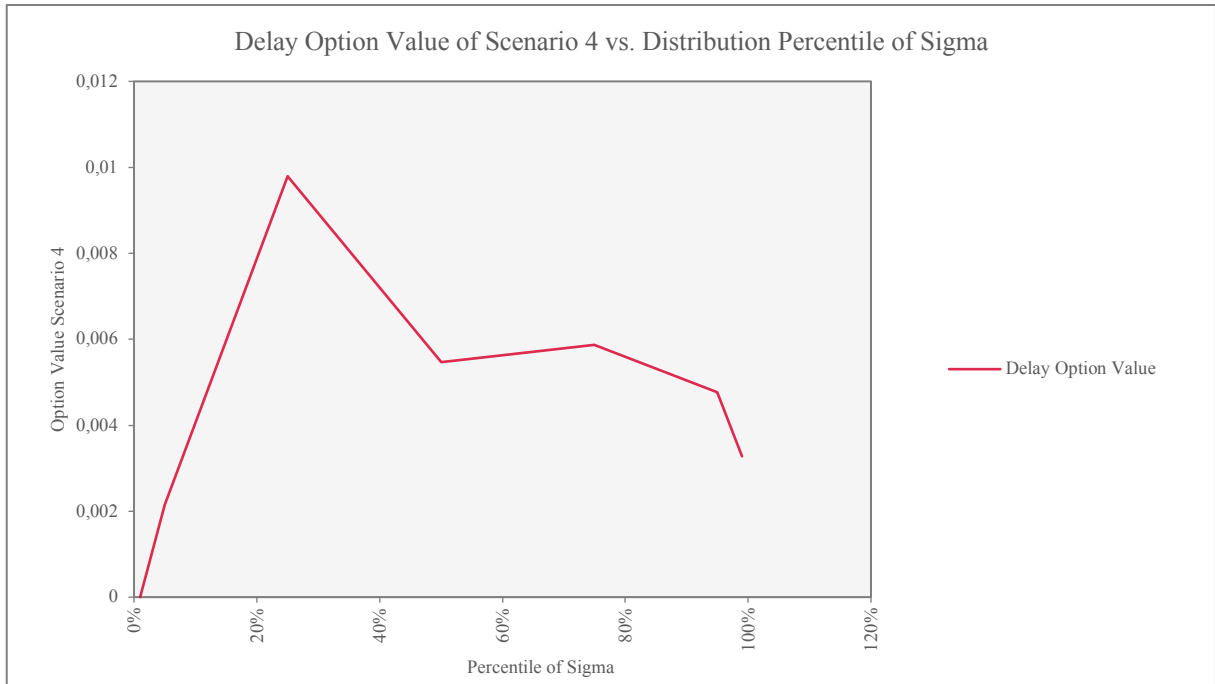

Appendix I: Sigma vs. Delay Option Value Scenario 4.

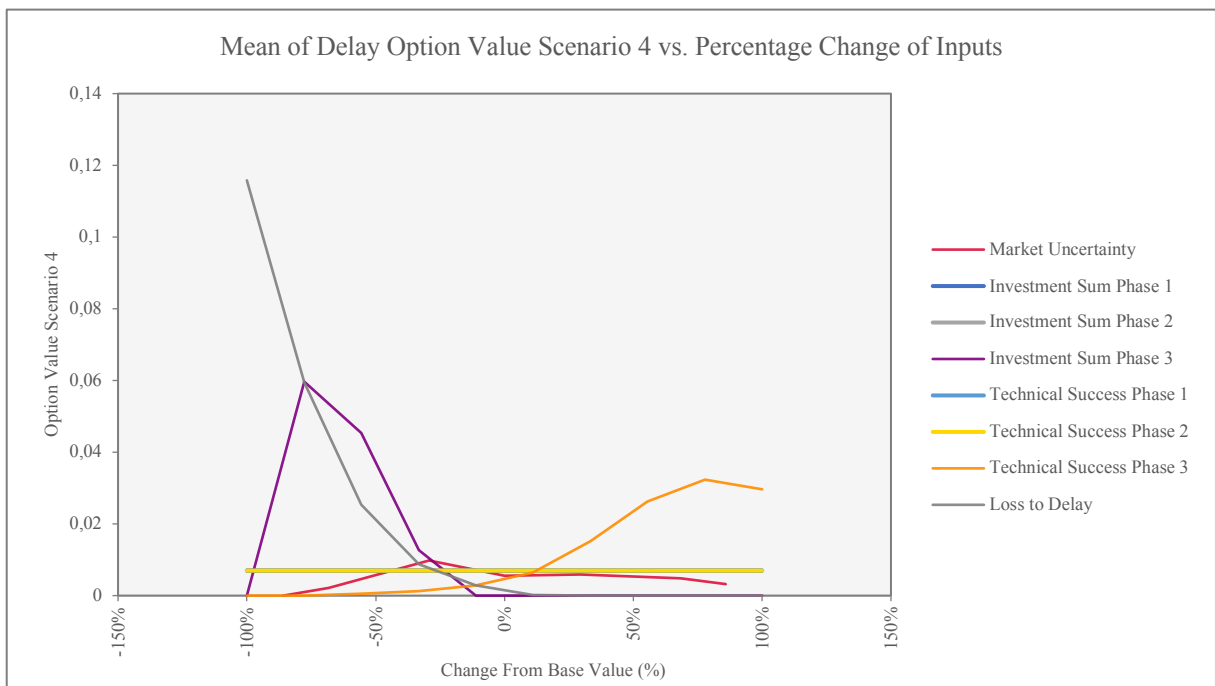

Appendix J: Spider Plot for Input Parameters in Scenario 4.